



INSTALLATION INSTRUCTIONS	Accessory	Application	Publications No. All 37138
	ATF AND POWER STEERING FLUID COOLERS	2006-2008 PILOT	Issue Date JUNE 2007

PARTS LIST

**Power Steering Fluid Cooler (sold separately):
P/N 53765-S9V-800**

Power steering fluid cooler

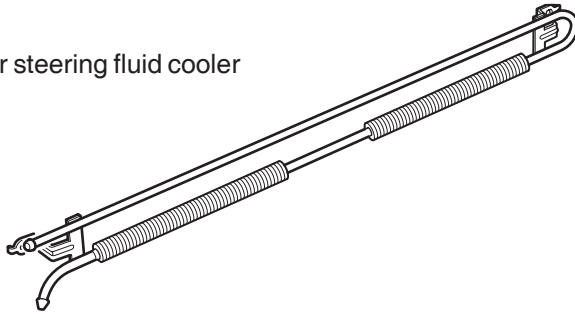

**ATF Cooler (sold separately):
P/N 06255-PVJ-315**

ATF Cooler

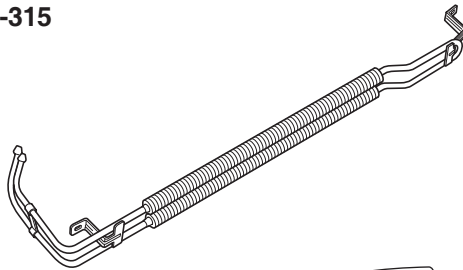

Long ATF Hose

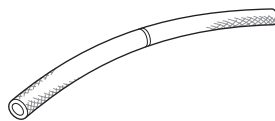

Short ATF Hose



Hose spacer



2 Washer-bolts, 6 x 12 mm



3 Hose clamps



Rearview mirror hang-tag

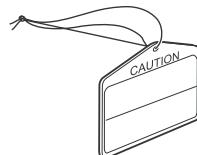

TOOLS AND SUPPLIES REQUIRED

- Flat-tip screwdriver
- 10 mm Socket
- Ratchet
- 6" Extension
- Drain pan
- Pliers
- Blanket

INSTALLATION

Customer Information: The information in this installation instruction is intended for use only by skilled technicians who have the proper tools, equipment, and training to correctly and safely add equipment to your vehicle. These procedures should not be attempted by "do-it-yourselfers."

NOTE:

- Be careful not to damage the front bumper and other finished surfaces of the body. Rest the front bumper on a blanket during the installation.
- Install the power steering fluid cooler before you install the ATF cooler.

1. Open the hood, and remove the eleven short clips that secure the bulkhead cover.

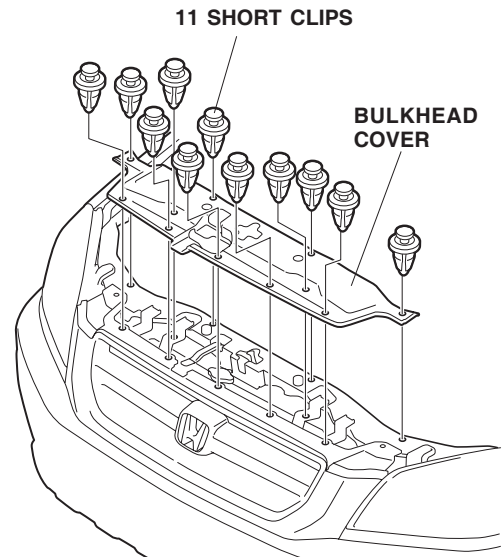

- Remove the four short clips, two self-tapping screws, four bolts, and two long clips that secure the front bumper.

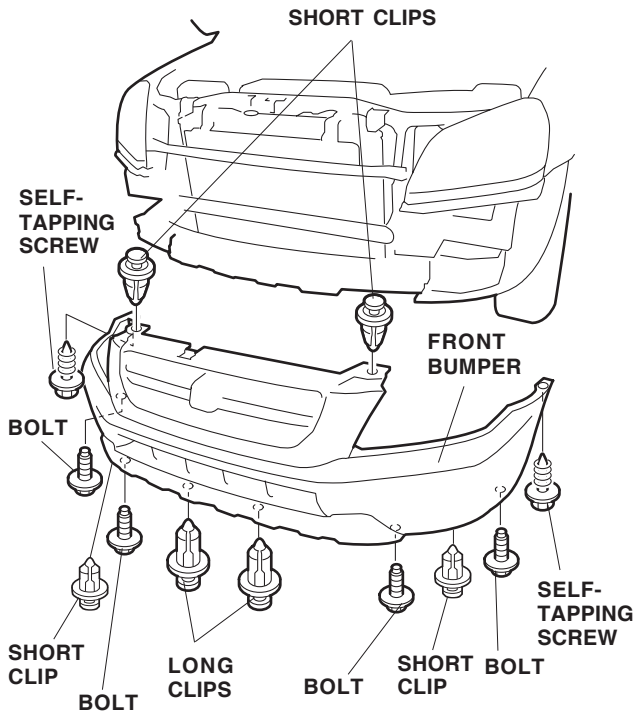

- Pull the front bumper out toward you; if equipped, disconnect the fog light harness connectors. Remove the front bumper, and rest it on a blanket to prevent damage.
- Remove the splash shield (15 clips).

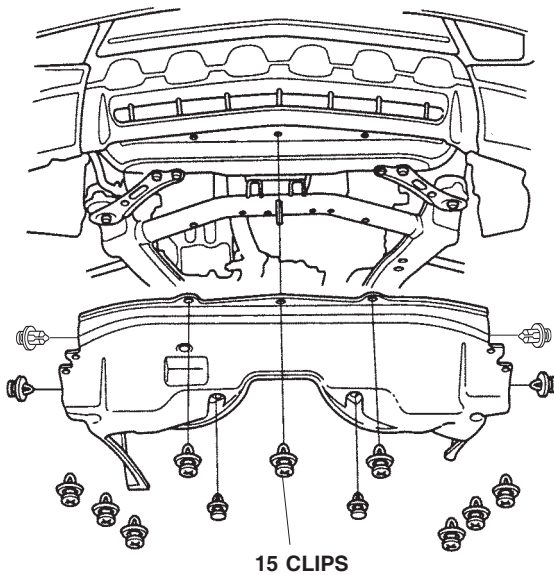

Installing the Power Steering Fluid Cooler

- Loosen the upper and lower hose clamps connected to the existing power steering fluid cooler.

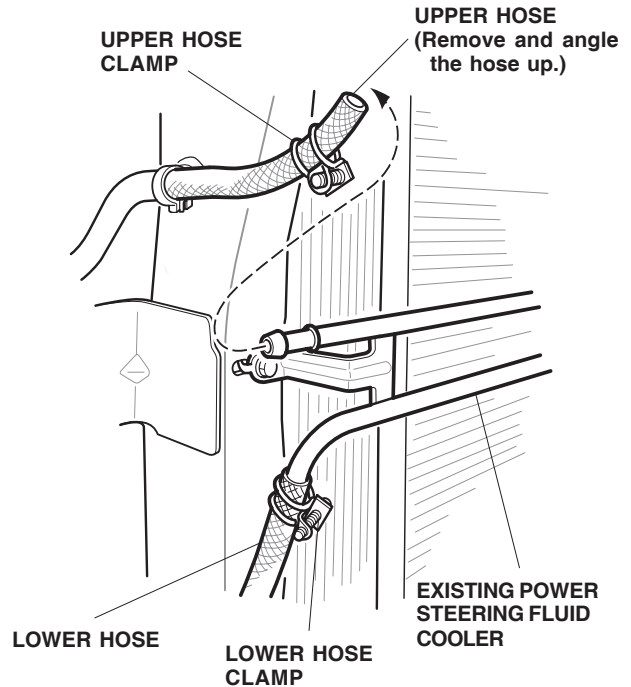

- With a drain pan under the vehicle, remove the upper (reservoir) hose from the cooler. Angle the hose up to prevent any excess fluid from leaking out.
- With an assistant holding the fluid cooler, remove the two bracket bolts, disconnect the lower hose, and remove the fluid cooler. Set the fluid cooler aside; it will not be reused.

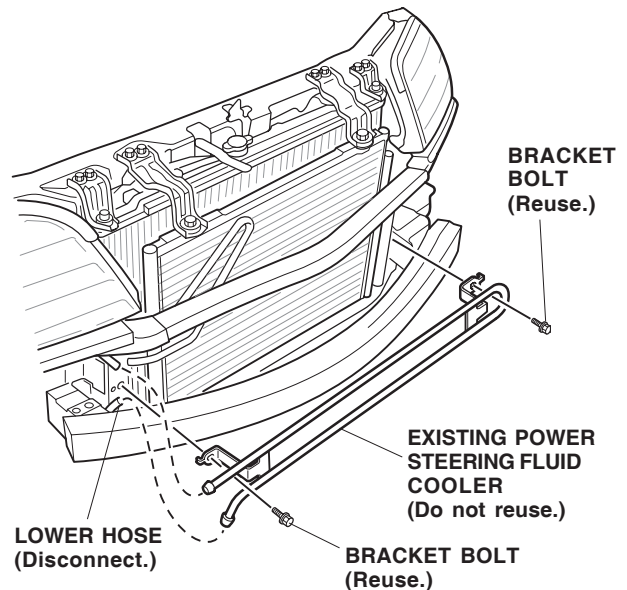

- Attach the lower hose to the new power steering fluid cooler, and fit the cooler into position on the front bulkhead. Reinstall the two bracket bolts, and torque the bolts to 7 N·m (5 lb-ft).

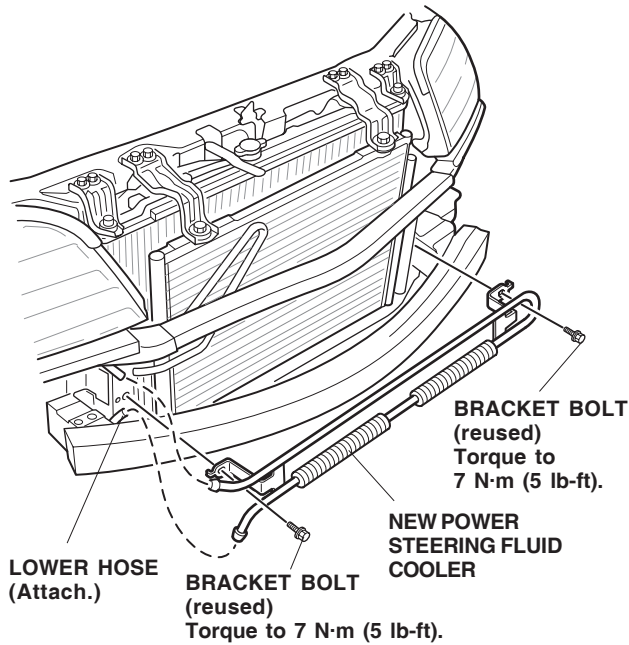

- Reinstall the upper hose. Make sure that the hose is pushed firmly against the stop on the cooler and that the dot on the upper hose is facing forward. Tighten the upper hose clamp to the specification shown.

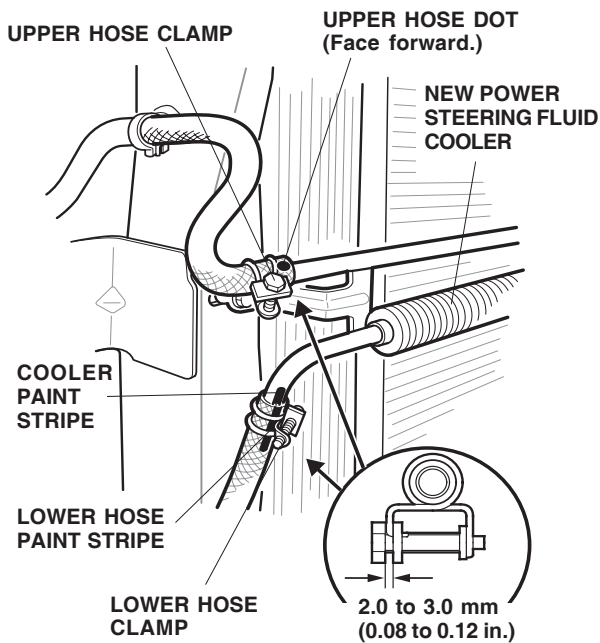

- Align the paint stripe on the lower hose with the paint stripe on the cooler, then tighten the lower hose clamp to the specification shown.

Installing the ATF Cooler

- Get the ATF hoses and the ATF cooler. Attach the new hoses to the cooler as shown.

NOTE: If four new hose clamps are not supplied with the kit, reuse one of the existing hose clamps.

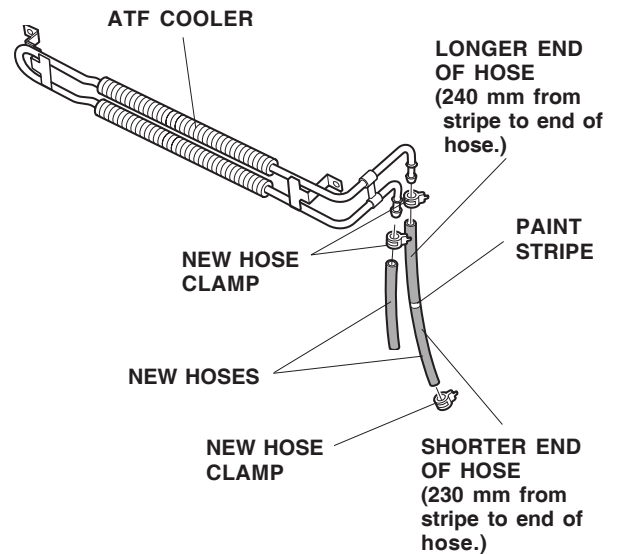

- Route the hose installed on the ATF cooler through the bulkhead, and fit the ATF cooler into position on the front bulkhead. Install the two 6 x 12 mm washer-bolts from the kit through the ATF cooler and into the threaded holes in the front bulkhead. Torque the bolts to 7 N·m (5 lb-ft).

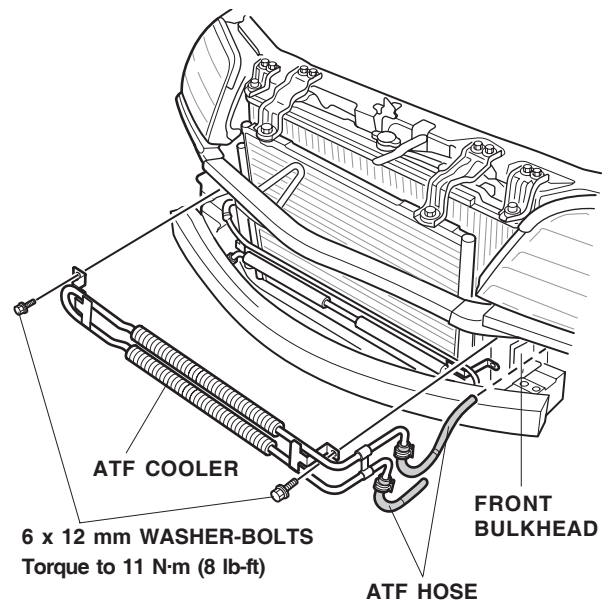

13. Remove the ATF return hose from the transmission, and from the radiator transmission cooler. Set the existing hose aside; it will not be reused. Attach the short ATF hose (return hose) from the new cooler to the radiator return hose fitting and secure them with an existing hose clamp.

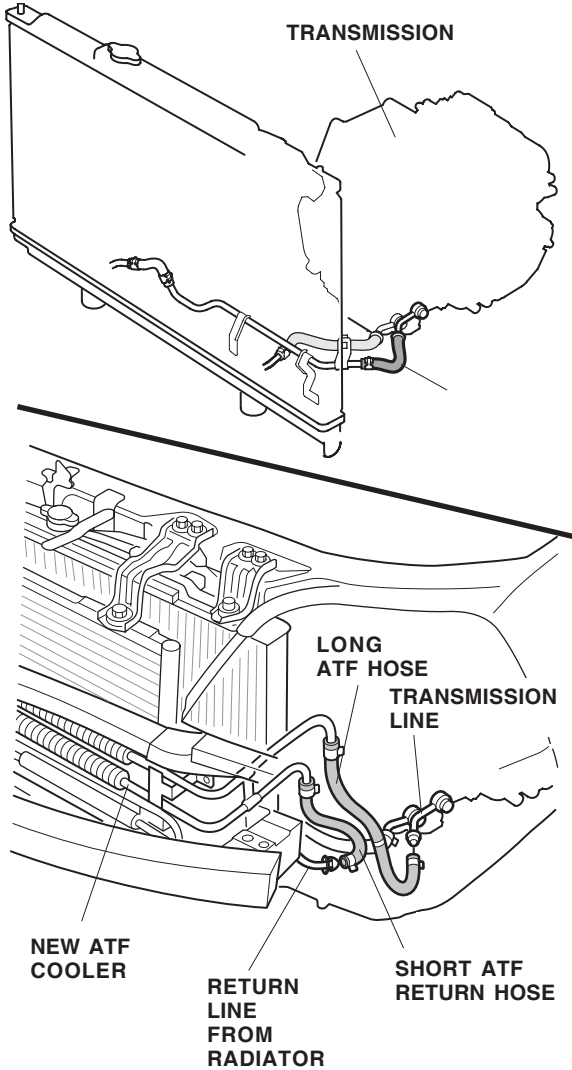

14. Attach the long ATF hose to the transmission line where you removed the return hose using one new hose clamp.

15. Attach the hose spacer between the two ATF hoses.

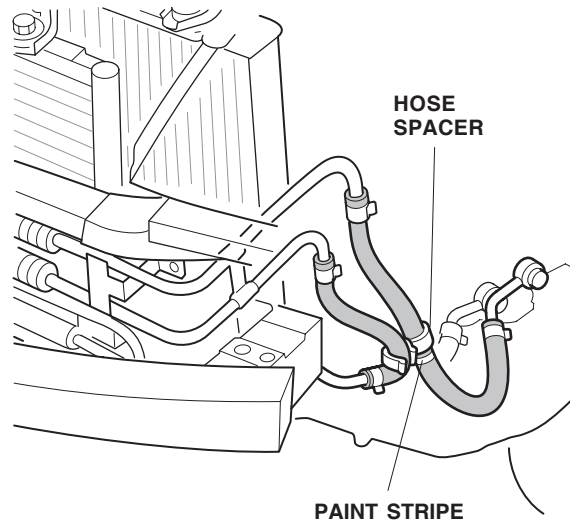

16. Fill the power steering fluid to the full level of the reservoir.
17. Start the engine, and check for fluid leaks; repair as necessary.
18. Check the ATF fluid level, and refill as necessary.
19. With the engine running, turn the steering wheel all the way clockwise and all the way counterclockwise several times; then turn back to the straight-ahead position. Recheck the power steering fluid level, and refill as necessary.
20. Test-drive the vehicle, and make sure you turn the steering wheel lock-to-lock. During the test-drive, listen for any noise or any abnormal feeling in the steering. After the test-drive, check the reservoir fluid level, and inspect for any fluid leaks. Refill as necessary.
21. Reinstall the splash shield.
22. Reinstall the front bumper. If equipped, make sure you plug in the fog light connectors. Reinstall the bulkhead cover.
23. Place the ATF cooler hang-tag around the rearview mirror.