



INSTALLATION INSTRUCTIONS

Accessory
AUTOMATIC DAY/NIGHT MIRROR

Application
2006 ACCORD HYBRID

Publications No.
All 31207
Issue Date
OCT 2005

PARTS LIST

Automatic Day/Night Mirror Kit
P/N 08V03-SDA-100A

Day/night mirror

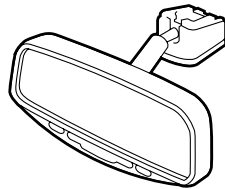

Mirror spring



Owner's manual

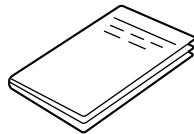

Attachment Kit (sold separately)
P/N 08V03-SDA-101A

Upper mirror cover

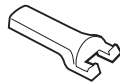

Lower mirror cover



Long upper mirror cover
(Not used)

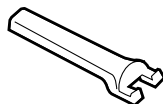

Long lower mirror cover
(Not used)

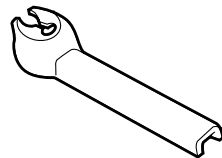

Mirror harness



2 EPT sealers
(1 not used)

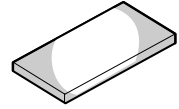

5 Wire ties

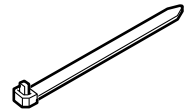

TOOLS AND SUPPLIES REQUIRED

Phillips screwdriver

Flat-tip screwdriver

Clip remover

Isopropyl alcohol

Small flat-tip screwdriver

Scissors

Ratchet

8 mm Socket

Eye protection (face shield, safety goggles, etc.)

Tape measure

Drill

7 mm Drill bit

Long nose pliers

Illustration of the Day/Night Mirror installed on the Vehicle

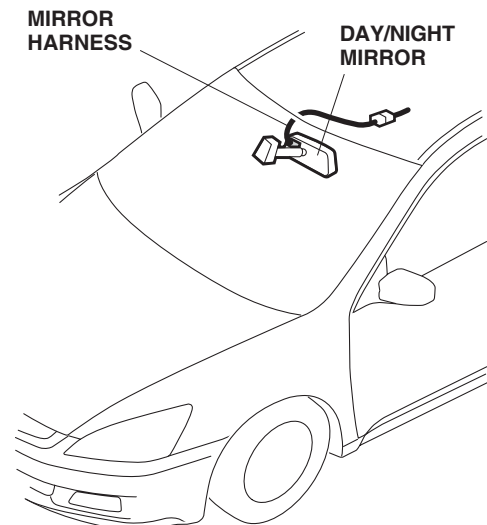

INSTALLATION

Customer Information: The information in this installation instruction is intended for use only by skilled technicians who have the proper tools, equipment, and training to correctly and safely add equipment to your vehicle. These procedures should not be attempted by “do-it-yourselfers.”

1. Make sure you have the anti-theft code for the radio, then write down the audio presets.
2. Disconnect the negative cable from the battery.
3. Remove the left and right lenses from the roof console (six retaining tabs).

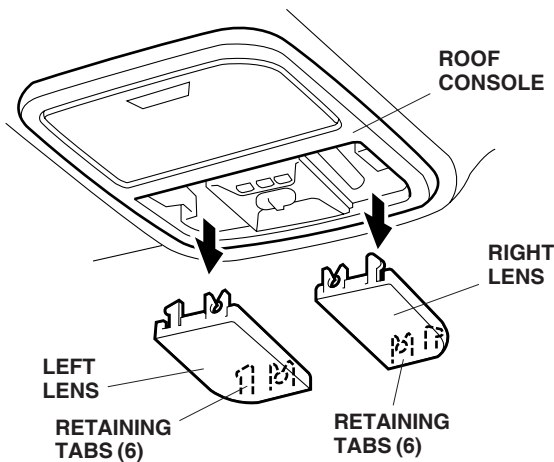

4. Remove the roof console (two bolts, two ground bolts and unplug two connectors).

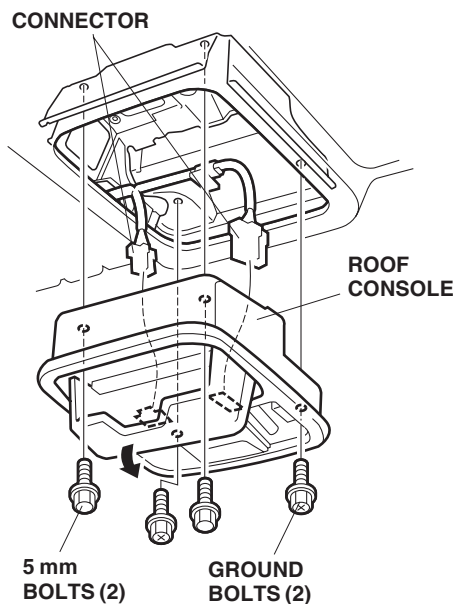

5. Remove the sunvisor holders. Using a flat-tip screwdriver, push the hook and turn the holder 90°, then pull it out.

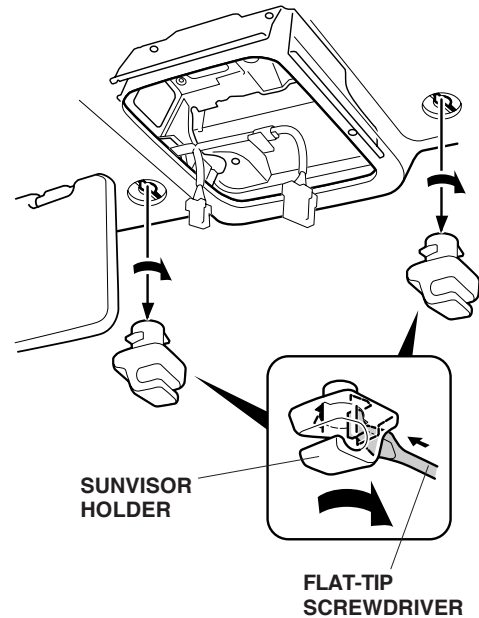

6. Remove the rearview mirror from the holder by rotating the stay 90° clockwise.

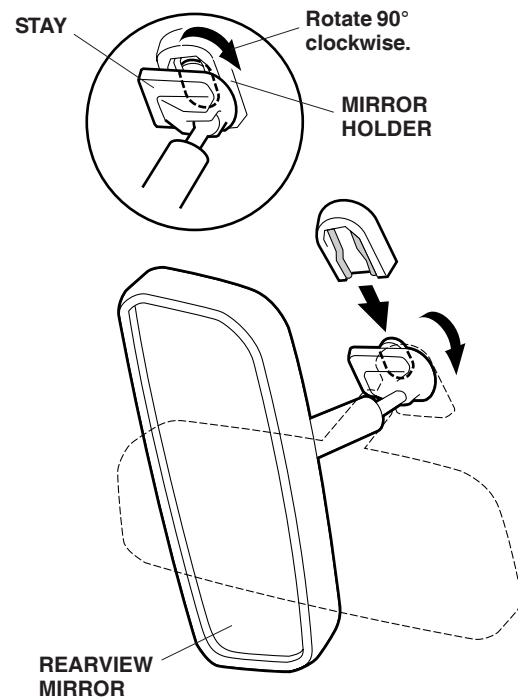

- Replace the mirror spring. Slide the day/night mirror stay onto the mirror holder, then turn the mirror stay counterclockwise as shown.

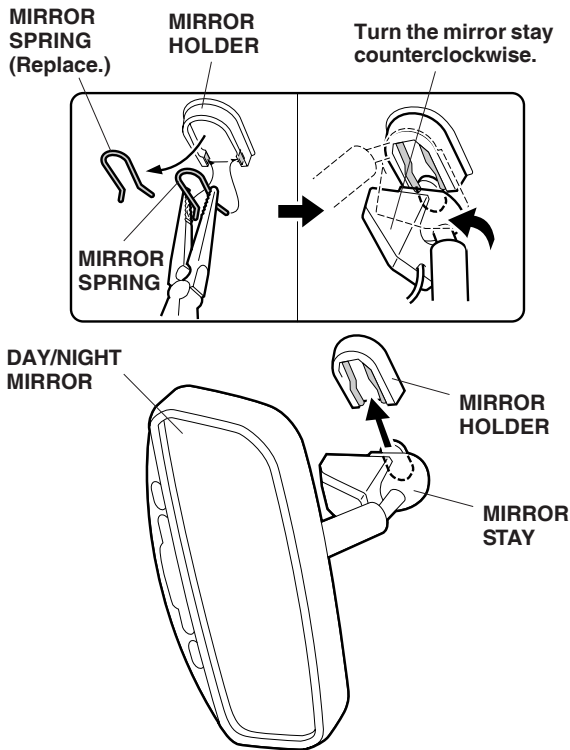

- Plug the mirror harness 7-pin connector into the rear of the mirror, then route the 3-pin connector up and out through the roof lining as shown.

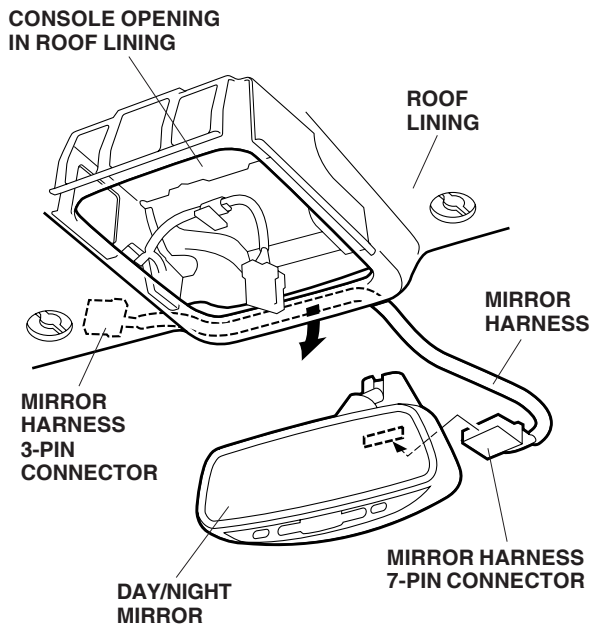

- On the lower mirror cover, measure and cut off the ribs shown.

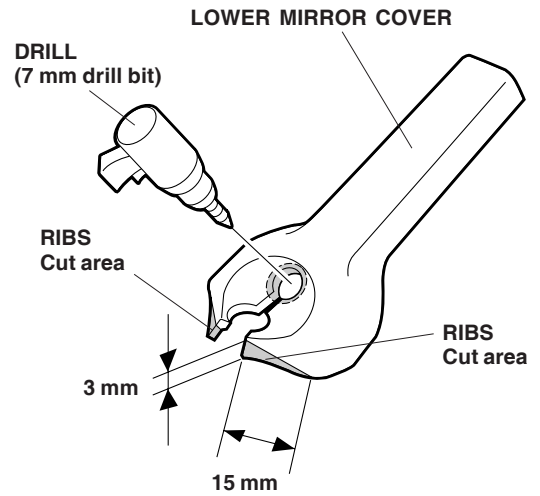

- While wearing eye protection, drill a 7 mm hole through the existing hole on the lower mirror cover as shown.
- Measure the mirror harness in the area shown. Slide the end of the upper mirror cover into the lower mirror cover, then route the mirror harness through the grooves in the covers. Attach the lower mirror cover to the stay of the mirror and slide the upper mirror cover to the edge of the roof lining.

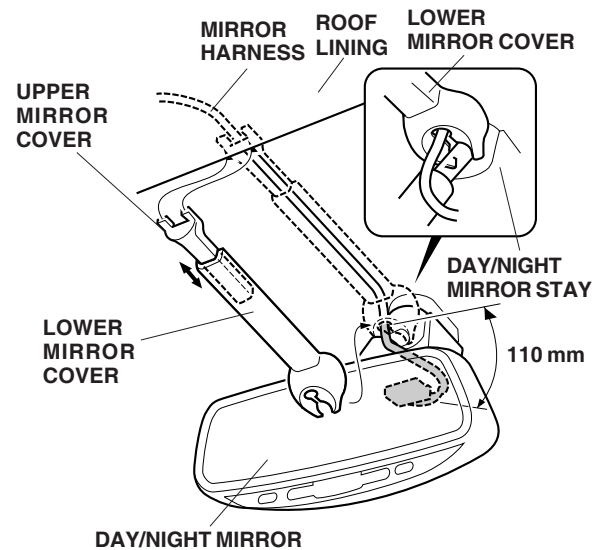

- Remove the dummy connector from the vehicle harness 3-pin connector, then connect the vehicle harness 3-pin connector to the mirror harness 3-pin connector. Make sure to plug the vehicle harness 3-pin connector into the mirror harness 3-pin connector and not into the interior light 3-pin connector.

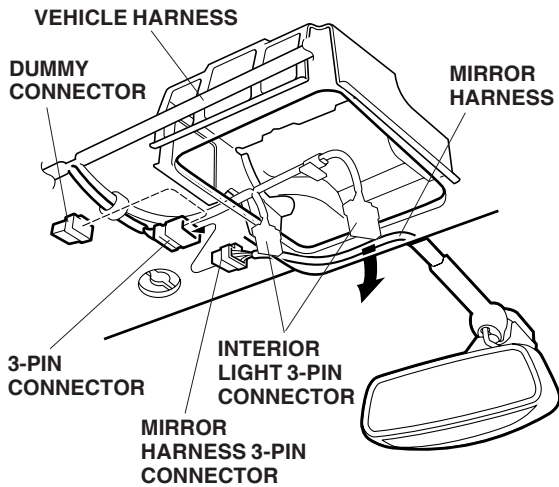

- Using isopropyl alcohol, thoroughly clean the areas where the EPT sealers will attach.

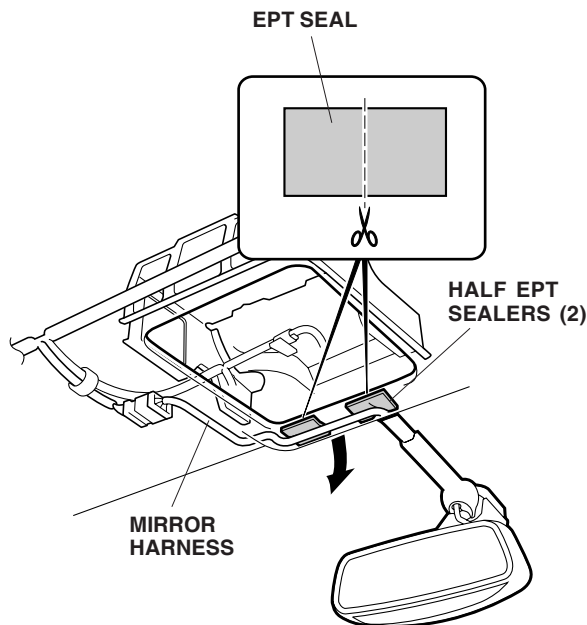

- Using scissors, cut one EPT sealer in half vertically.
- Attach the mirror harness to the roof lining with two halves of EPT sealer in the area shown.

- Check that all wire harnesses and cables are routed properly and that all connectors are plugged in.
 - Reinstall all removed parts. Check that all clips and fasteners are installed securely.
 - Reconnect the negative cable to the battery.
 - Enter the customer's radio anti-theft code, and reset the audio presets.
 - Reset the clock.
 - If the IMA battery level gauge (BAT) displays zero segments, start the engine, and hold it between 3,500 rpm and 4,000 rpm (in Park or Neutral) until the IMA battery level gauge (BAT) displays at least three segments.
 - Check the operation of the automatic day/night mirror according to the owner's manual supplied.
- NOTE: Whenever the battery is disconnected, the driver's window AUTO function is disabled.
- Start the engine. Push down on the driver's window switch until the window is fully open.
 - Pull up on the driver's window switch fully to close the window completely, then hold the switch for 2 seconds.
 - Test the window AUTO function.