



# INSTALLATION INSTRUCTIONS

Accessory	Application	Publications No. <b>All 23634</b>
<b>TRAILER HITCH</b>	<b>2003-2004 PILOT</b>	Issue Date <b>MAY 2002</b>

## PARTS LIST

Trailer hitch

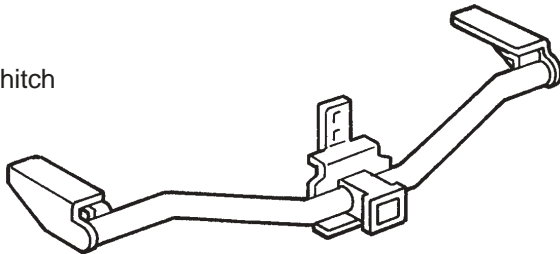

Ball mount

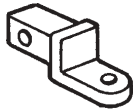

Hitch pin



Hitch pin clip



8 Bolts, 12 x 40 mm



2 Bolts, 10 x 30 mm



2 Bolts, 8 x 20 mm



8 Plain washers, 12 mm



2 Plain washers, 10 mm



2 Plain washers, 8 mm



8 Spring washers, 12 mm



2 Spring washers, 10 mm



2 Spring washers, 8 mm



2 Spacers



Receiver cover

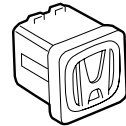

## TOOLS AND SUPPLIES REQUIRED

Ratchet

13 mm, 17 mm, and 19 mm Sockets

Utility knife

Torque wrench

## INSTALLATION

**Customer Information:** The information in this installation instruction is intended for use only by skilled technicians who have the proper tools, equipment, and training to correctly and safely add equipment to your vehicle. These procedures should not be attempted by "do-it-yourselfers."

### NOTE:

- Optional ATF and power steering coolers are required when installing the trailer hitch. Have the recommended coolers available so they can be installed.
- Be careful not to damage the rear bumper or other finished surfaces of the body.

- Using diagonal cutters, trim the left side of the rear bumper in the area shown. Trim the right side of the rear bumper the same way.

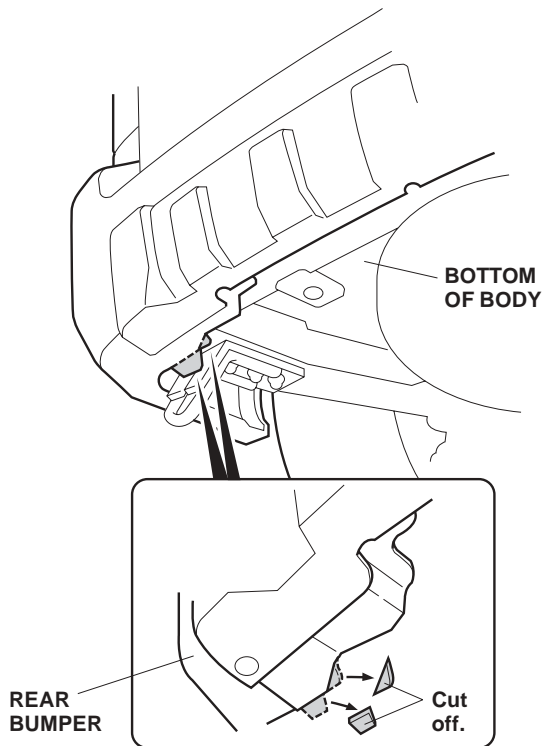

- Remove the tow hook (three bolts). Save the tow hook and bolts for your customer.

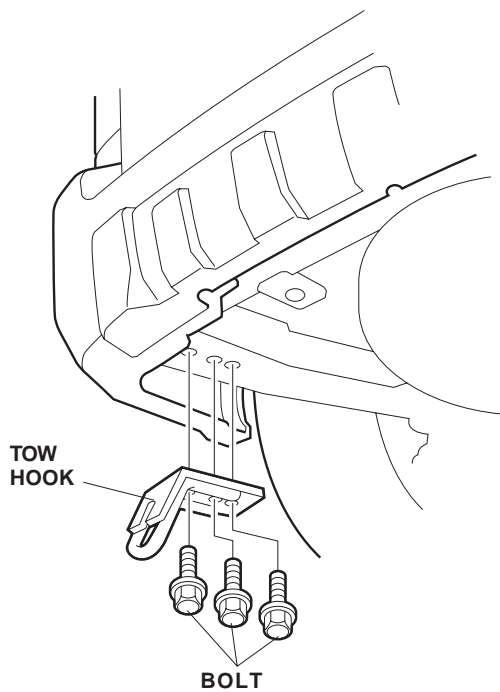

- With the help of an assistant, install the trailer hitch on the body, using the eight 12 x 40 mm bolts, eight 12 mm plain washers, and eight 12 mm spring washers. Do not tighten the bolts yet.

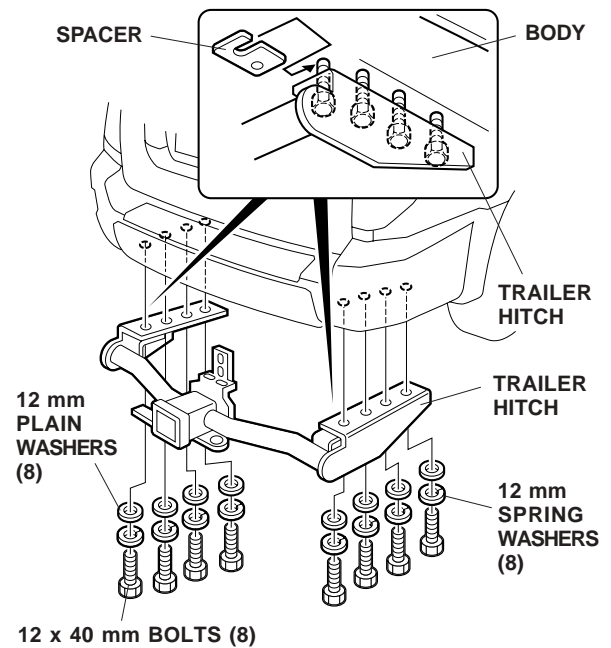

- Insert one spacer between the trailer hitch and the body. Do not tighten the trailer hitch bolts yet.

- Loosely install the two 10 x 30 mm bolts, and the two 8 x 20 mm bolts all with plain washers and with spring washers.

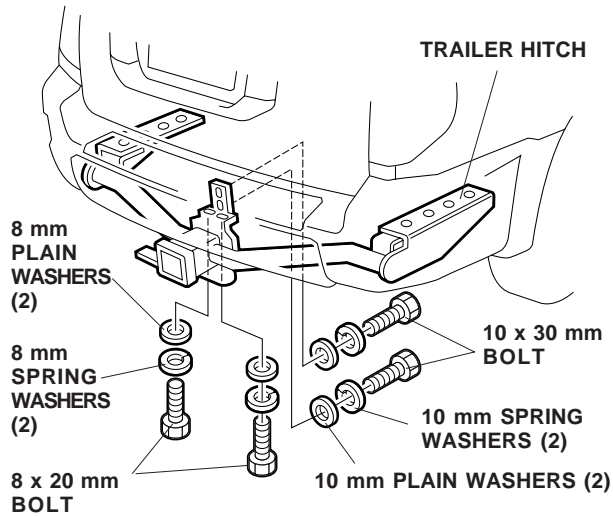

- Torque the trailer hitch mounting bolts in this order:

**1**

- Two 8 x 20 mm bolts to 27 N-m (20 lb-ft).

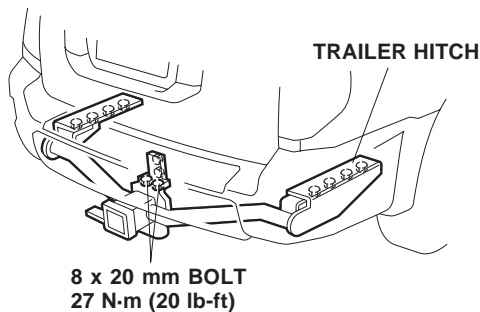

**2**

- Two 10 x 30 mm bolts to 46 N-m (33 lb-ft).

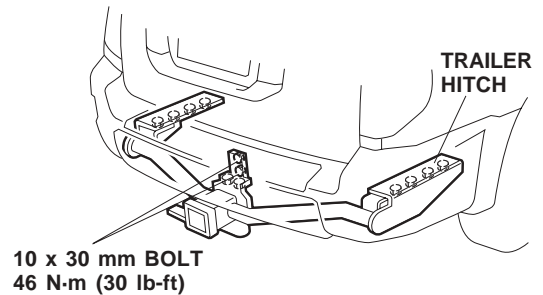

**3**

- Eight 12 x 40 mm bolts (installed in step 3) to 80 N-m (58 lb-ft).

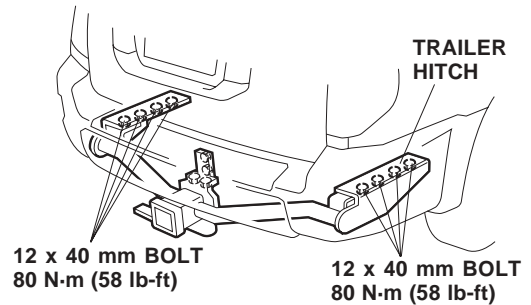

- Slide the ball mount into the opening at the end of the trailer hitch.

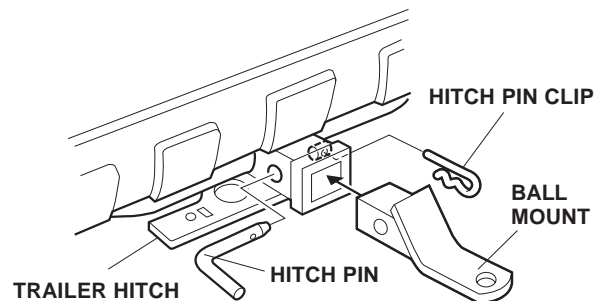

- Slide the hitch pin through the trailer hitch and ball mount, then install the hitch pin clip in the hole in the end of the hitch pin.

**NOTE:** Tell your customer to retighten the trailer hitch nuts and bolts after about 620 miles (1,000 km) of use.

**Put a Copy of This Page in the Glove Box for Your Customer**

**Installing the Receiver Cover**

Whenever you remove the hitch pin clip, the hitch pin, and the ball mount, securely store them in the cargo area. Then install the receiver cover into the opening at the end of the trailer hitch. When you reinstall the ball mount, store the receiver cover in the cargo area.

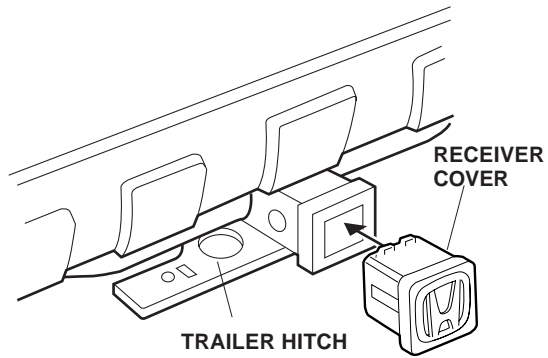



# INSTALLATION INSTRUCTIONS

Accessory  
**ATF AND POWER STEERING  
FLUID COOLERS**

Application  
**2003 PILOT**

Publications No.  
**All 23596**  
Issue Date  
**MAY 2002**

## PARTS LIST

**Power Steering Fluid Cooler (sold separately):  
P/N 53765-S9V-800**

Power steering fluid cooler

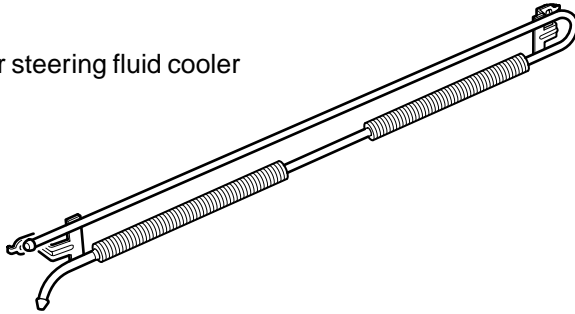

**ATF Cooler (sold separately):  
P/N 06255-PVG-305**

ATF Cooler

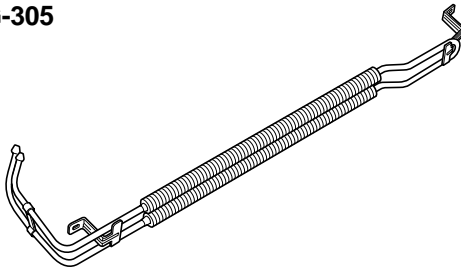

ATF Hose

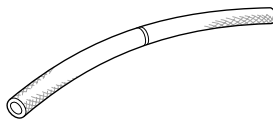

Hose spacer



2 Washer-bolts, 6 x 12 mm



3 Hose clamps



Rearview mirror hang-tag

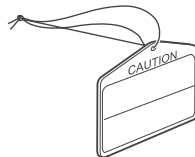

## TOOLS AND SUPPLIES REQUIRED

- Flat-tip screwdriver
- 10 mm Socket
- Ratchet
- 6" Extension
- Drain pan
- Pliers
- Blanket

## INSTALLATION

**Customer Information:** The information in this installation instruction is intended for use only by skilled technicians who have the proper tools, equipment, and training to correctly and safely add equipment to your vehicle. These procedures should not be attempted by "do-it-yourselfers."

### NOTE:

- Be careful not to damage the front bumper and other finished surfaces of the body. Rest the front bumper on a blanket during the installation.
  - Install the power steering fluid cooler before you install the ATF cooler.
1. Open the hood, and remove the eleven short clips that secure the bulkhead cover.

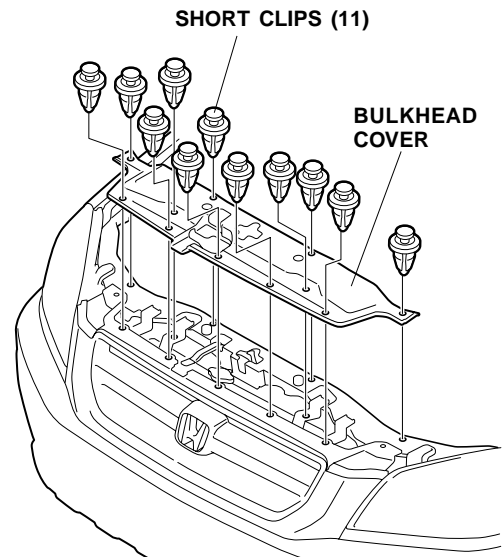

- Remove the four short clips, two self-tapping screws, four bolts and two long clips that secure the front bumper.

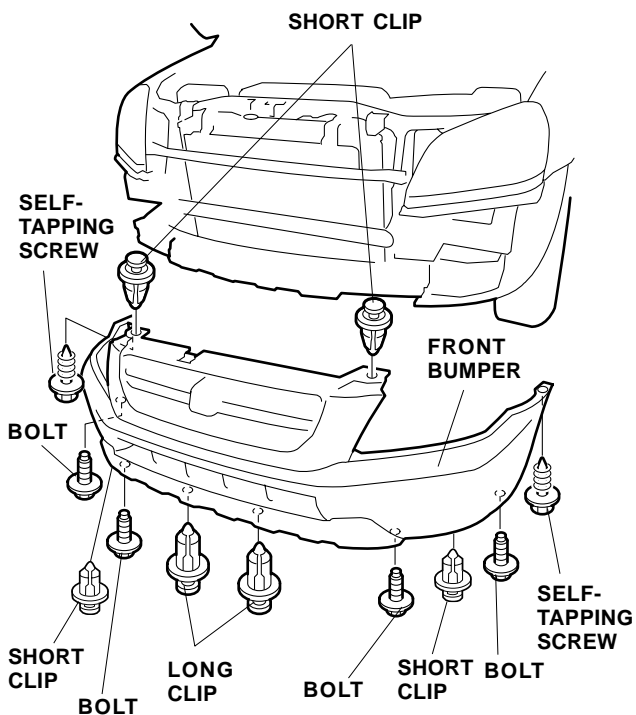

- Pull the front bumper out toward you, then if equipped, disconnect the fog light harness connectors. Remove the front bumper, and rest it on a blanket to prevent damage.
- Remove the splash shield (15 clips).

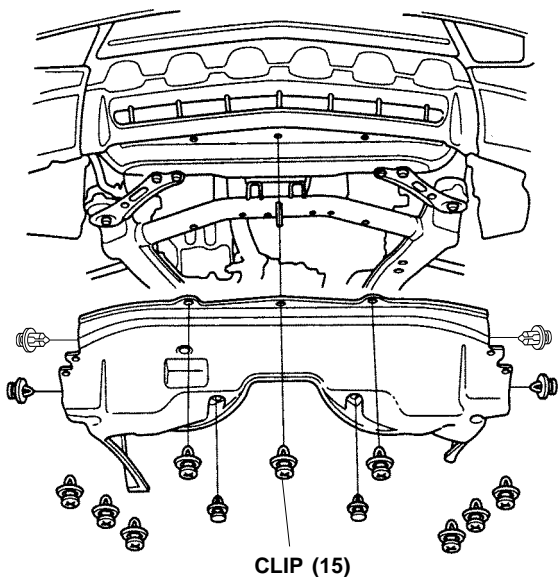

### Installing the Power Steering Fluid Cooler

- Loosen the upper and lower hose clamps connected to the existing power steering fluid cooler.

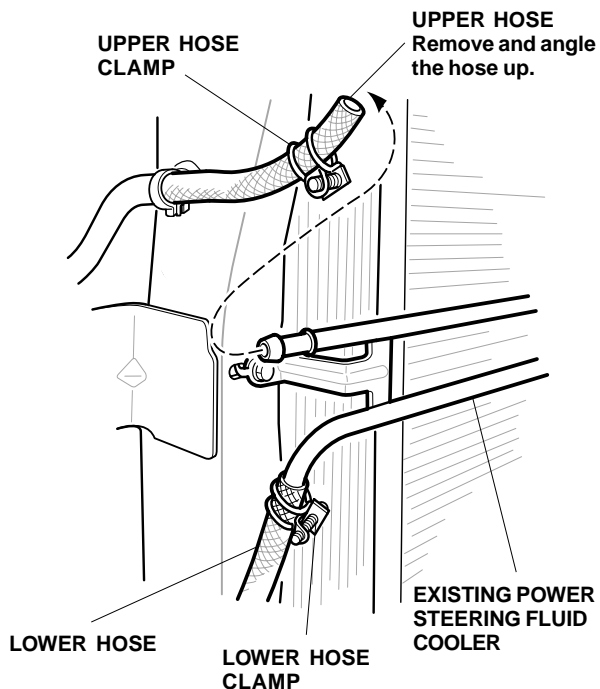

- With a drain pan under the vehicle, remove the upper (reservoir) hose from the cooler. Angle the hose up to prevent any excess fluid from leaking out.
- With an assistant holding the fluid cooler, remove the two bracket bolts, disconnect the lower hose, and remove the fluid cooler. Set the fluid cooler aside; it will not be reused.

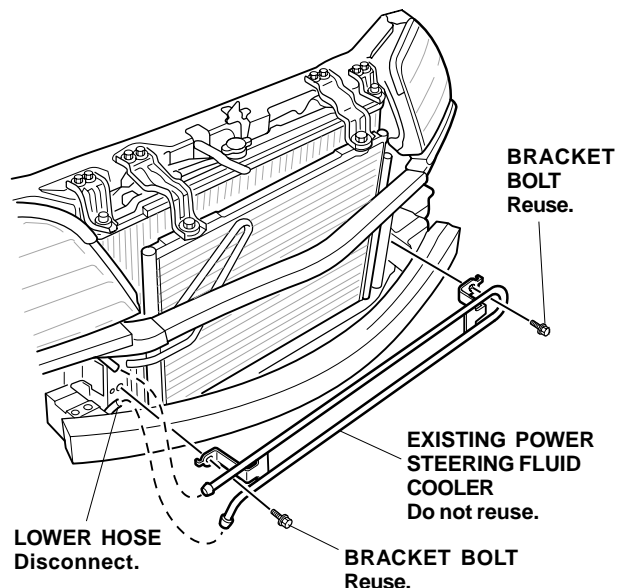

- Attach the lower hose to the new power steering fluid cooler, and fit the cooler into position on the front bulkhead. Reinstall the two bracket bolts, and torque the bolts to 7 N·m (5 lb-ft).

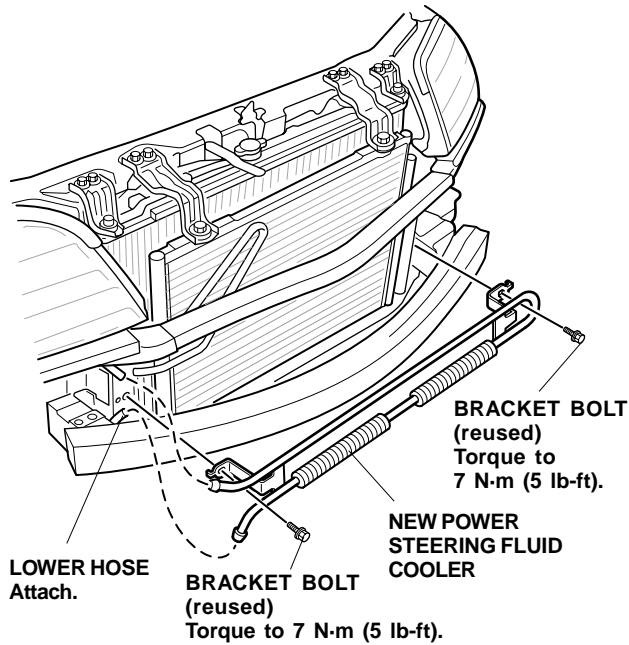

- Reinstall the upper hose. Make sure that the hose is pushed firmly against the stopper on the cooler and that the dot on the upper hose is facing forward. Tighten the upper hose clamp to the specification shown.

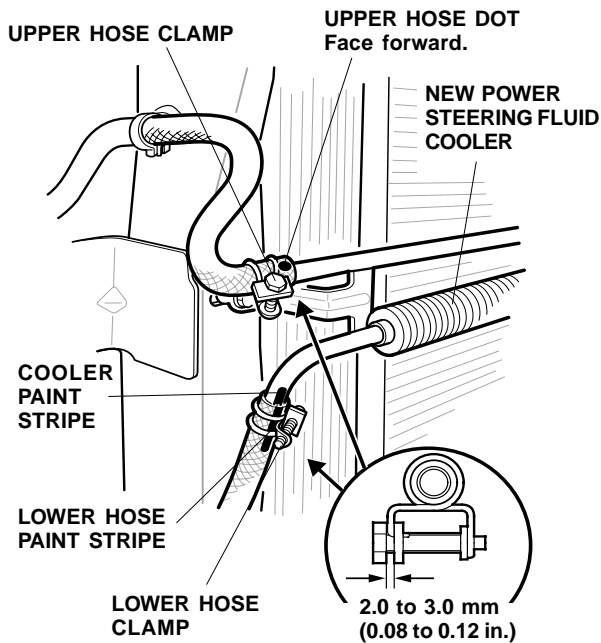

- Align the paint stripe on the lower hose with the paint stripe on the cooler, then tighten the lower hose clamp to the specification shown.

## Installing the ATF Cooler

- Get the ATF hose and the ATF cooler. Attach the short end (from the white stripe) of the hose to the upper cooler line with one new hose clamp from the kit.

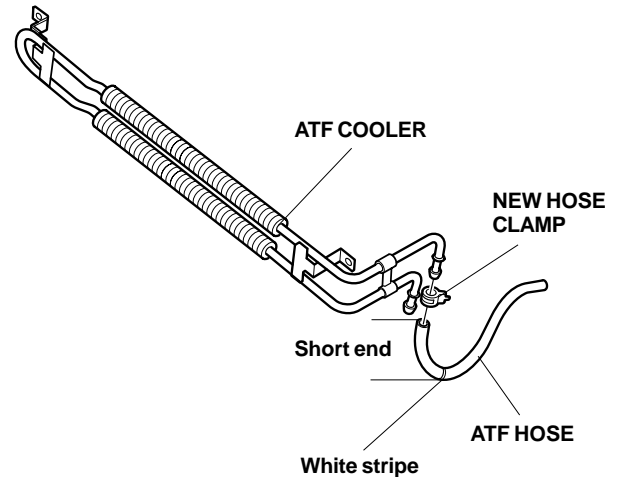

- Route the hose installed on the ATF cooler through the bulkhead, and fit the ATF cooler into position on the front bulkhead. Install the two 6 x 12 mm washer-bolts from the kit through the ATF cooler and into the threaded holes in the front bulkhead. Torque the bolts to 7 N·m (5 lb-ft).

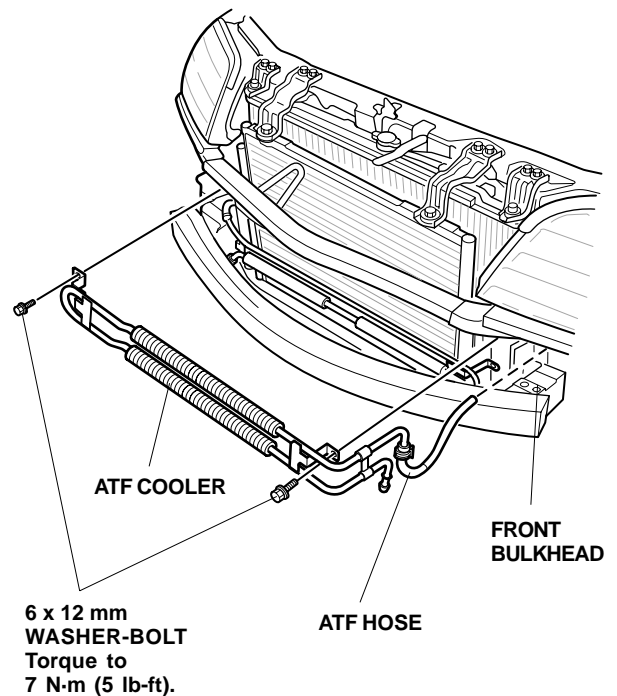

13. With a drain pan under the vehicle, remove the ATF return hose from the transmission side, and attach the return hose to the lower ATF cooler line using one new hose clamp.

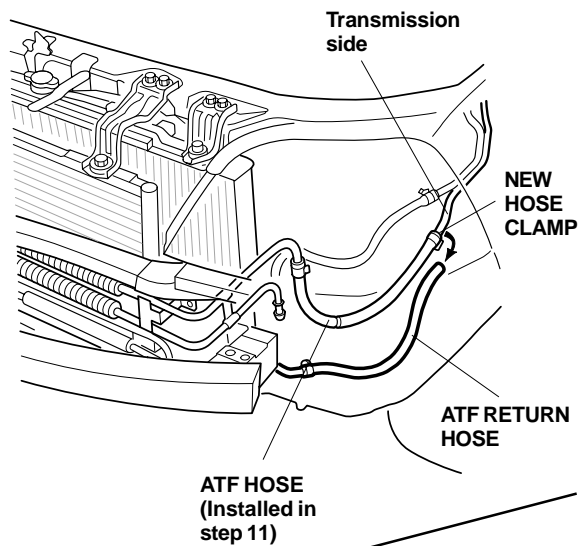

14. Attach the ATF hose (installed in step 11) to the transmission side where you removed the return hose using one new hose clamp.

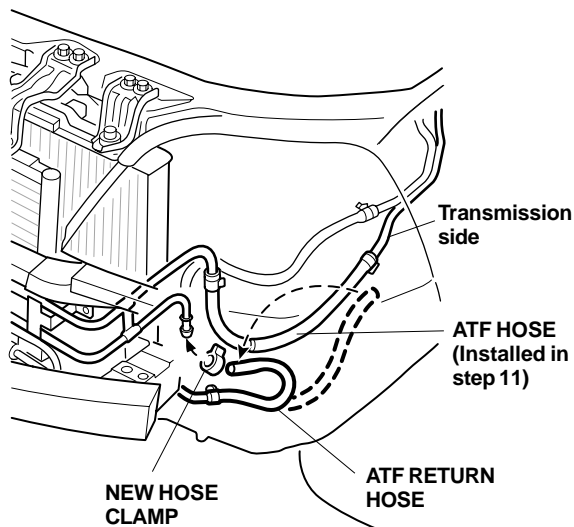

15. Attach the hose spacer between the two hoses at the white line painted on the ATF hose.

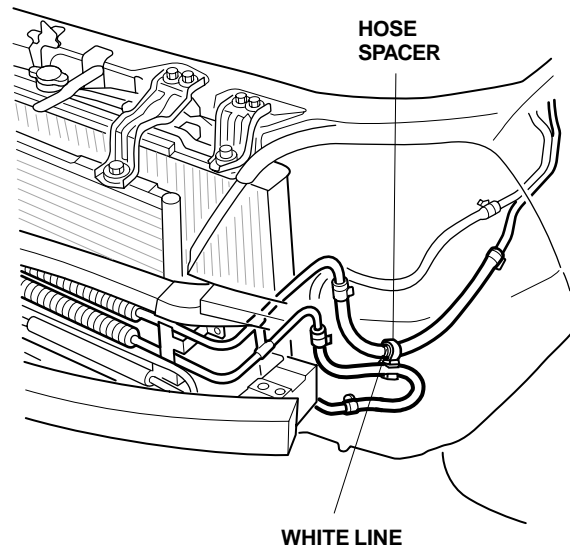

16. Fill the power steering fluid to the Full level of the reservoir.
17. Start the engine, and check for fluid leaks; repair as necessary.
18. Check the ATF fluid level, and refill as necessary.
19. With the engine running, turn the steering wheel all the way clockwise and all the way counterclockwise several times; then turn back to the straight-ahead position. Recheck the power steering fluid level, and refill as necessary.
20. Test-drive the vehicle, and make sure you turn the steering wheel lock-to-lock. During the test-drive, listen for any noise or any abnormal feeling in the steering. After the test-drive, check the reservoir fluid level, and inspect for any fluid leaks. Refill as necessary.
21. Reinstall the splash shield.
22. Reinstall the front bumper. If equipped, make sure you plug in the fog light connectors.
23. Place the ATF cooler hang-tag around the rearview mirror.



# INSTALLATION INSTRUCTIONS

Accessory  
**TRAILER HITCH HARNESS**  
P/N 08L91-S9V-100

Application  
**2003 PILOT**

Publications No.  
**All 23642**

Issue Date  
**MAY 2002**

## PARTS LIST

Trailer hitch harness

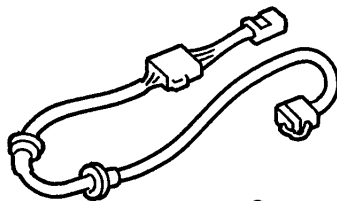

2 Short wire ties



2 Long wire ties



Clip



Bolt



Lock-nut



Bracket

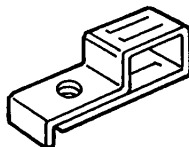

## TOOLS AND SUPPLIES REQUIRED

Flat-tip screwdriver

Diagonal cutters

Ratchet

10 mm Socket

Isopropyl alcohol

Shop towel

10 mm Combination wrench

Tape measure

## INSTALLATION

**Customer Information:** The information in this installation instruction is intended for use only by skilled technicians who have the proper tools, equipment, and training to correctly and safely add equipment to your vehicle. These procedures should not be attempted by "do-it-yourselfers."

### NOTE:

- Optional ATF and power steering coolers are required when installing the trailer hitch. Have the recommended coolers available so they can be installed.
- Be careful not to damage the rear bumper of other finished surfaces of the body.

1. Open the tailgate, and remove the cargo floor lid.

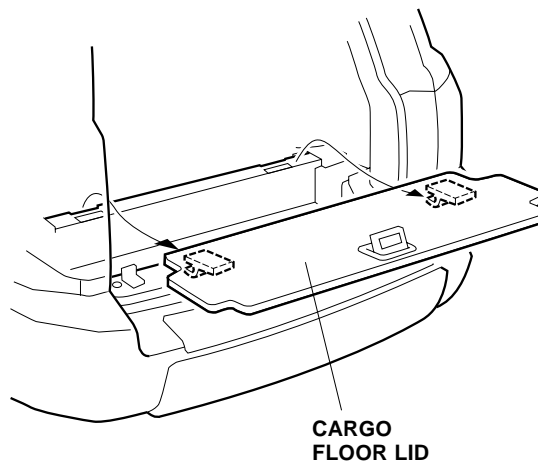

- Remove the tailgate weatherstrip, lift up the rear panel trim, and remove the rear panel trim (four clips and six retaining tabs).

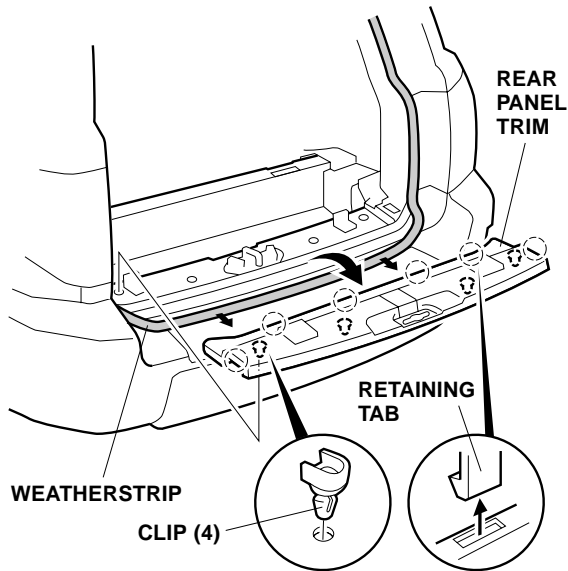

- Under the rear bumper on the driver's side of the vehicle, locate the large grommet in the body frame. Remove and discard the large grommet.

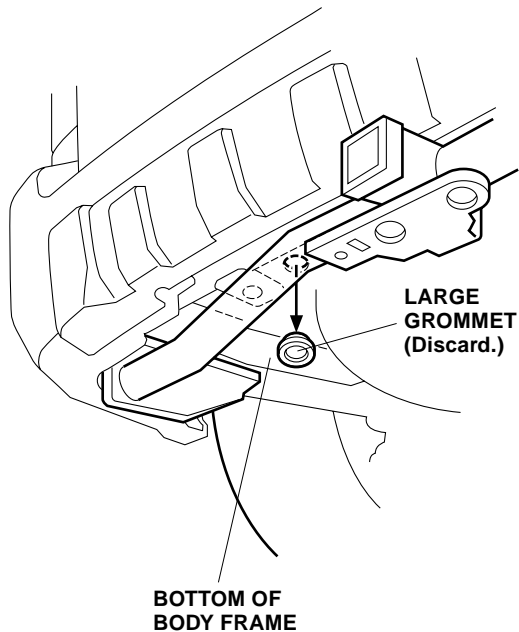

- Inside the vehicle, locate the grommet on the body panel. Remove and discard the grommet from the body panel.

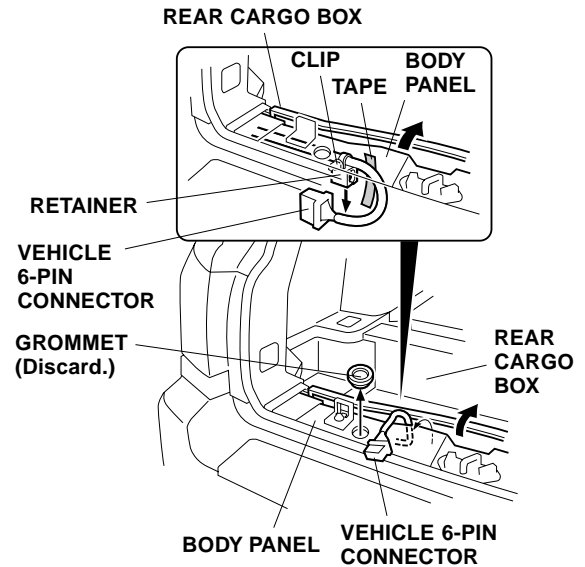

- Remove the tape on the vehicle 6-pin connector harness located in the space between the rear cargo box and the body panel, and pull out the vehicle 6-pin connector. Remove the harness from the retainer, but do not remove the clip.
- Route the trailer hitch harness 4-pin connector through the hole in the body panel and out through the hole in the bottom of the body.

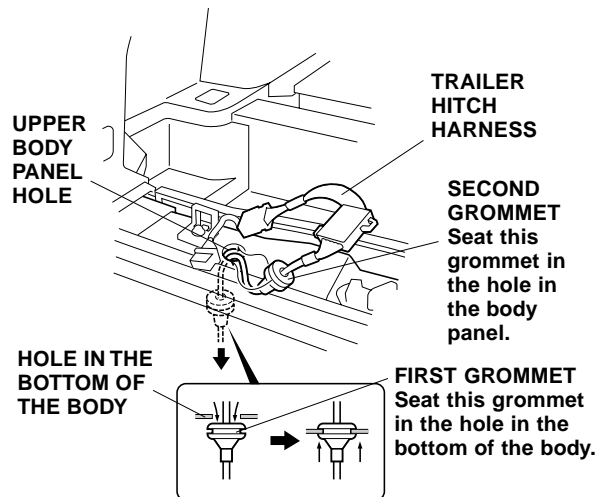

- Pull the first grommet through the upper body panel hole, and seat the first grommet in the hole in the bottom of the body. Seat the second grommet in the upper body panel hole.

- Using diagonal cutters, cut the ears off of the converter.

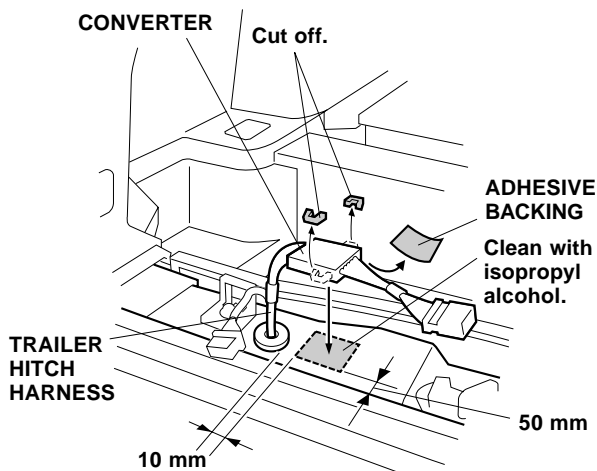

- Using the measurements shown, mark the location of the converter. Remove the adhesive backing from the back of the converter, then attach it to the body panel in the marked location. Before attaching, thoroughly clean the body panel surface with isopropyl alcohol.
- Plug the trailer hitch harness 6-pin into the vehicle harness 6-pin connector.

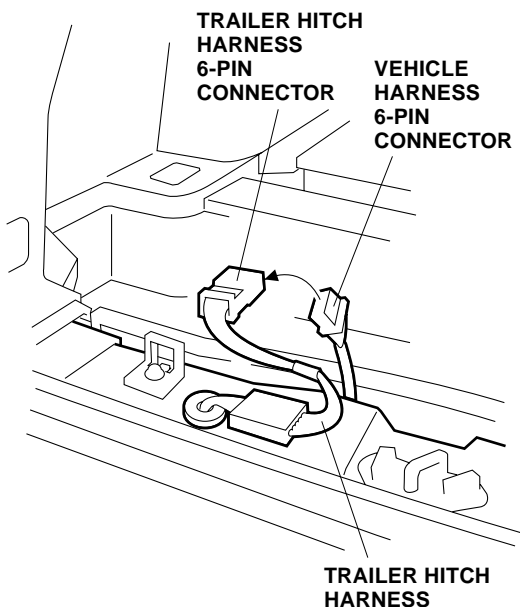

- Get the clip from the kit, and attach it to the 6-pin connector of the trailer hitch harness. Push the clip you just installed into the body panel hole.

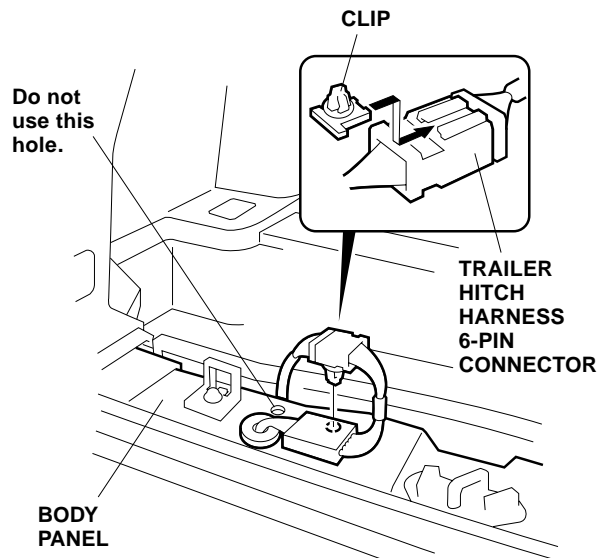

- Attach the socket of the trailer hitch harness to the bracket, and install the bracket to the trailer hitch with the bolt and lock-nut.

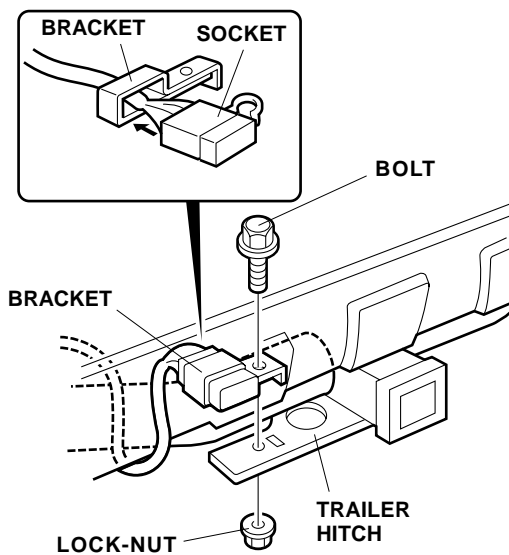

13. Secure the trailer hitch harness to the trailer hitch with the two long wire ties in the areas shown.

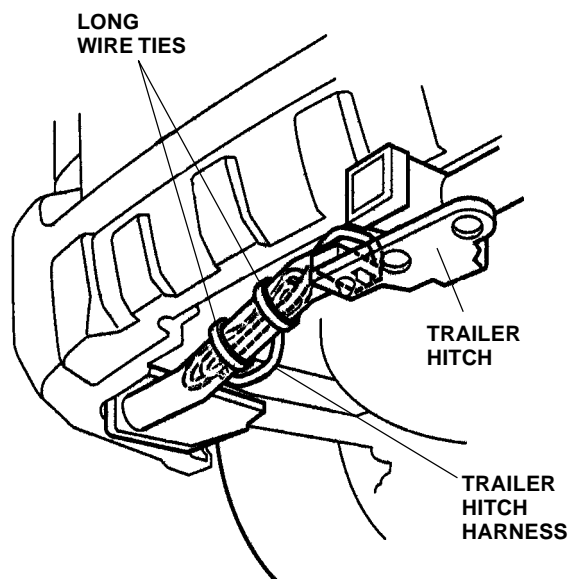

14. Reinstall the rear panel trim, the tailgate weatherstrip, and the cargo floor lid.

**Put a Copy of This Page in the Glove Box for Your Customer**

**FUSE LOCATIONS**

**Primary Under-Hood Fuse Box**

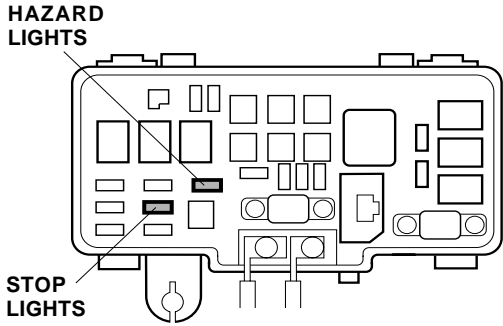

**Interior Fuse Box (Passenger's Side)**

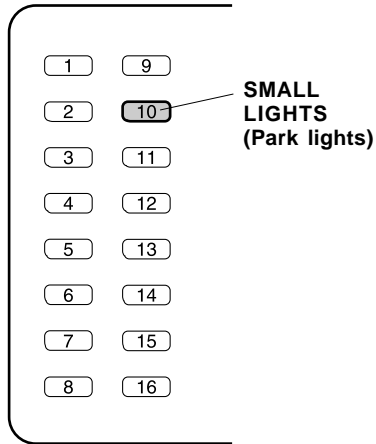

**Interior Fuse Box (Driver's Side)**

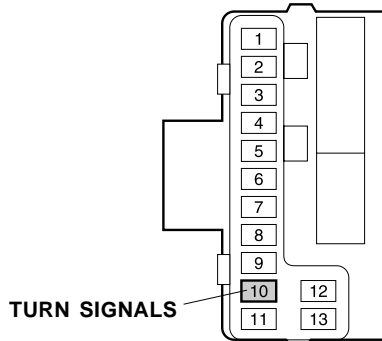

**WIRING INFORMATION**

**To Vehicle:**

- R Red = Brake
- Y Yellow = Left Turn
- G Green = Right Turn
- BR Brown = Small Lights (Park lights)
- W White = Ground

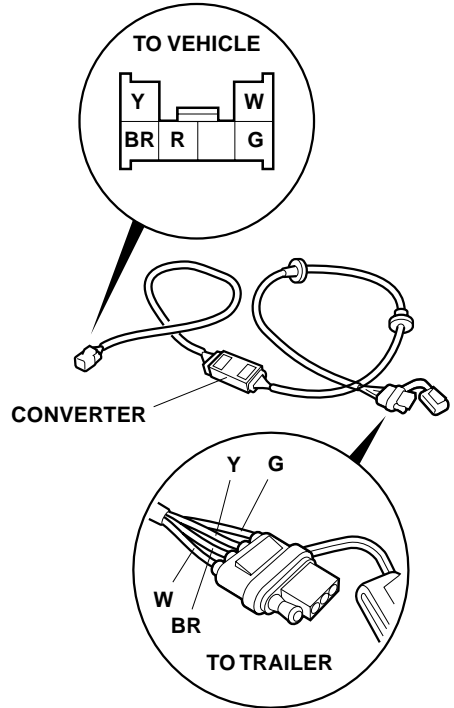

**To Trailer:**

- Y Yellow = Brake/Left Turn
- G Green = Brake/Right Turn
- BR Brown = Small Lights (Park lights)
- W White = Ground