



INSTALLATION INSTRUCTIONS

Accessory

FENDER FLARES

Application

2004-2005 PILOT

Publications No.

All 28055

Issue Date

SEP 2004

NOTE: This fender flare kit cannot be installed on a vehicle equipped with a full nose mask.

PARTS LIST

Left front bumper flare

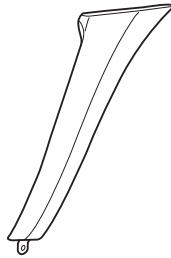

Left front fender flare

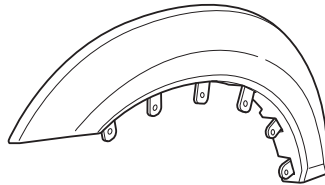

Left rear fender flare

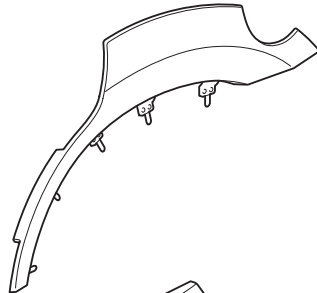

Left rear bumper flare



Left rear door flare



Left rear door flare holder

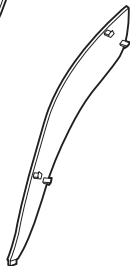

Right front bumper flare

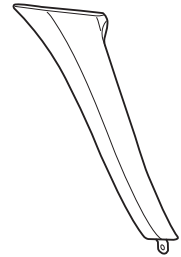

Right front fender flare

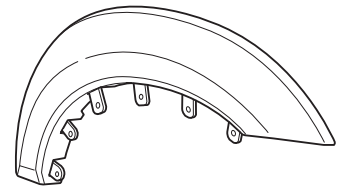

Right rear fender flare

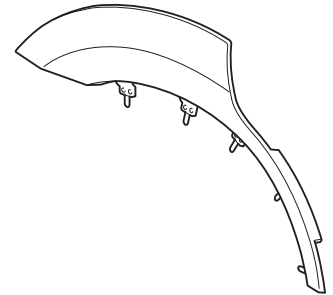

Right rear bumper flare

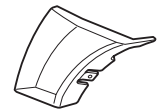

Right rear door flare



Right rear door flare holder

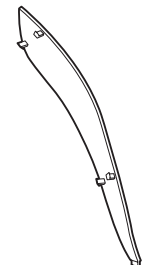

8 Self-tapping screws



6 Spring nuts



4 Clips



10 Alcohol pads

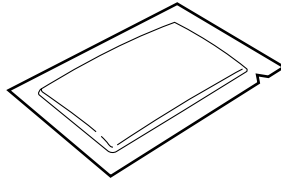

TOOLS AND SUPPLIES REQUIRED

Stubby Phillips screwdriver

Phillips screwdriver

Flat-tip screwdriver

Ratchet

10 mm Combination wrench

Isopropyl alcohol

Shop towel

Masking tape

Clip remover

INSTALLATION

Customer Information: The information in this installation instruction is intended for use only by skilled technicians who have the proper tools, equipment, and training to correctly and safely add equipment to your vehicle. These procedures should not be attempted by “do-it-yourselfers.”

NOTE:

- Be careful not to damage the finished surfaces of the body when installing the fender flares.
- This fender flare kit should be installed only when the ambient air temperature is 60°F (15°C) or above.
- To allow the adhesive to cure, do not wash the vehicle for 24 hours.
- These instructions show the left fender flares being installed; the same procedure applies to installing the right fender flares.

Installing the Front Bumper Flare

1. Remove the bumper bolt from the bottom of the front bumper.

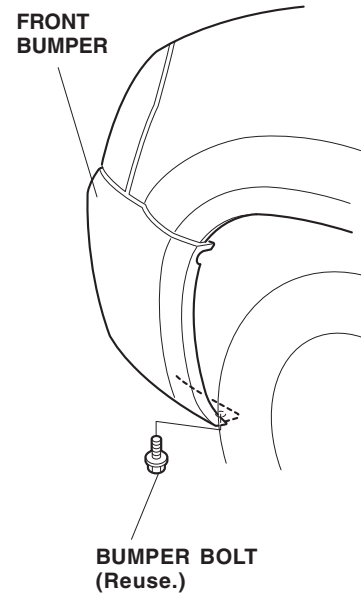

2. Align the ends of the front bumper flare with the front end of the front bumper, and bend the mounting tabs around the fender flange. Using a felt-tip pen, mark the edge of the front bumper through the three holes in the bumper flare. Remove the front bumper flare.

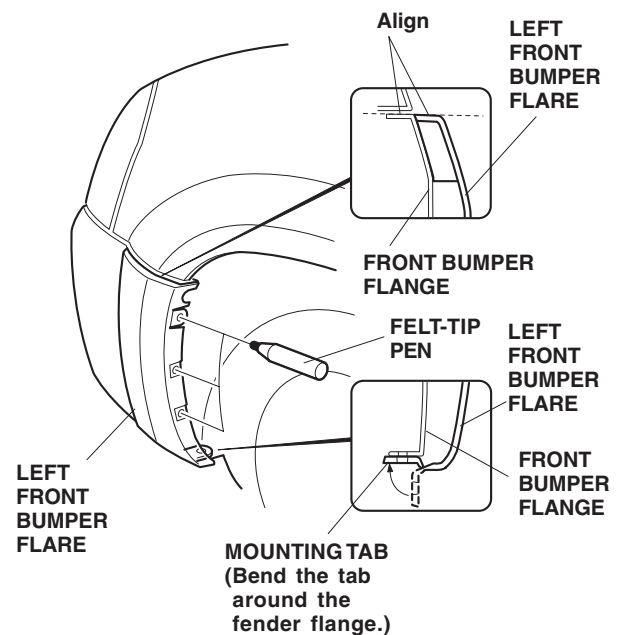

- Slide one spring nut over each of the three marks you made on the front bumper.

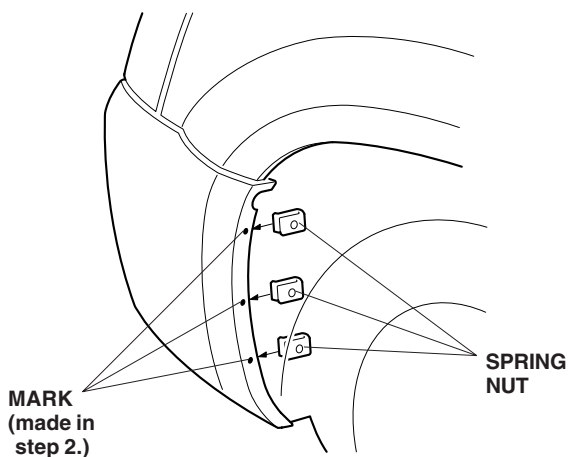

- Using an alcohol pad clean the front bumper where the front bumper flare will attach.
- On the inside of the left front bumper flare, remove 3 to 5 cm (1 to 2 in.) from each backing. Fold the ends back, and tape them to the front of the bumper flare. Remove and discard the upper and lower adhesive backing.

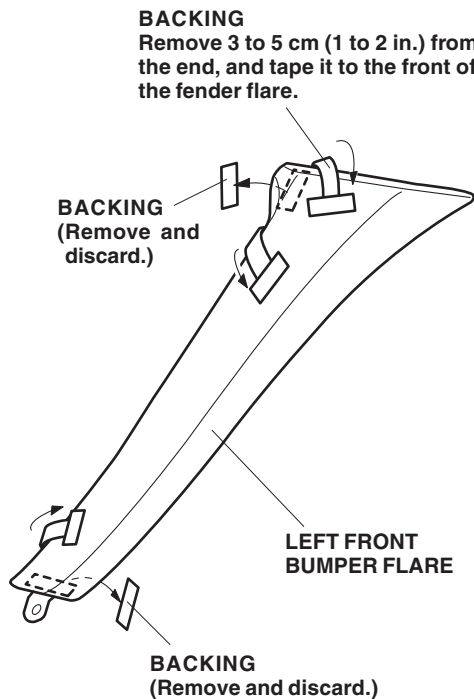

- Position the left front bumper flare on the front bumper and install the three self-tapping screws (from the kit) through the front bumper. Reinstall the bumper bolt you removed in step 1, but do not tighten the self-tapping screws or the bolt yet.

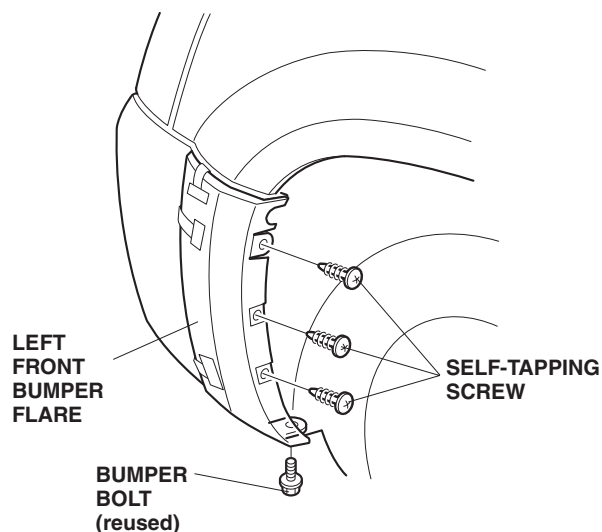

- Remove the backings from the left front bumper fender flare:
 - Slowly and carefully peel the backing from the left front bumper flare.
 - After removing all of the backings, press the left front bumper flare firmly against the front bumper with the palm of your hand for 30 seconds particularly at the edges. Make sure to apply enough pressure to ensure the adhesive tape sticks to the body.

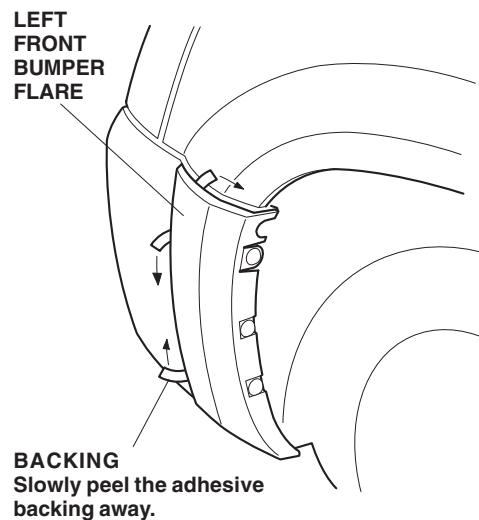

- Tighten the three self-tapping screws and the bumper bolt.

Installing the Front Fender Flare

- Remove the two self-tapping screws and four clips from the left front inner fender.

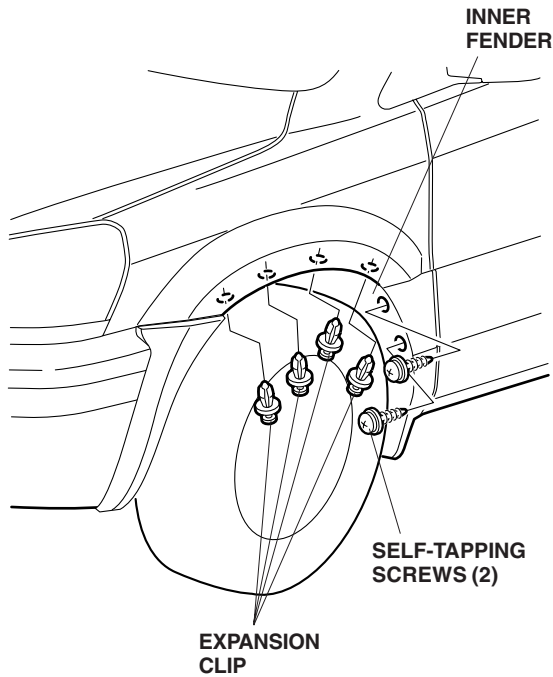

- Using an alcohol pad clean the front bumper where the front fender flare will attach.
- On the inside of the left front fender flare, remove 3 to 5 cm (1 to 2 in.) from the upper backing. Fold the end back, and tape it to the front of the fender flare. Remove and discard the two lower backings.

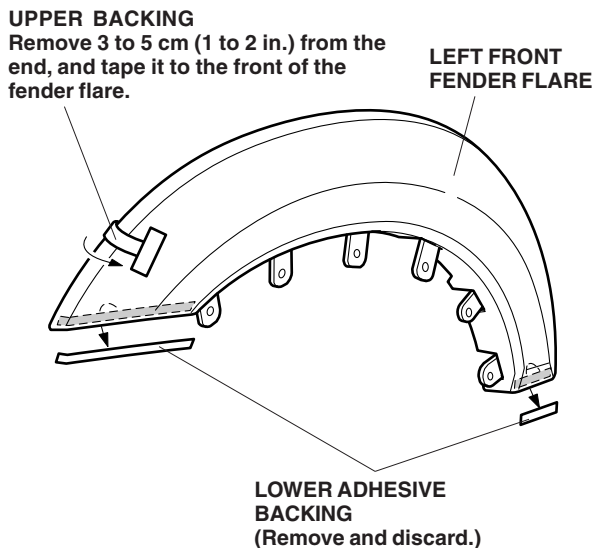

- Align the ends of the front fender flare with the front end of the front fender, and bend the mounting tabs around the fender flange.

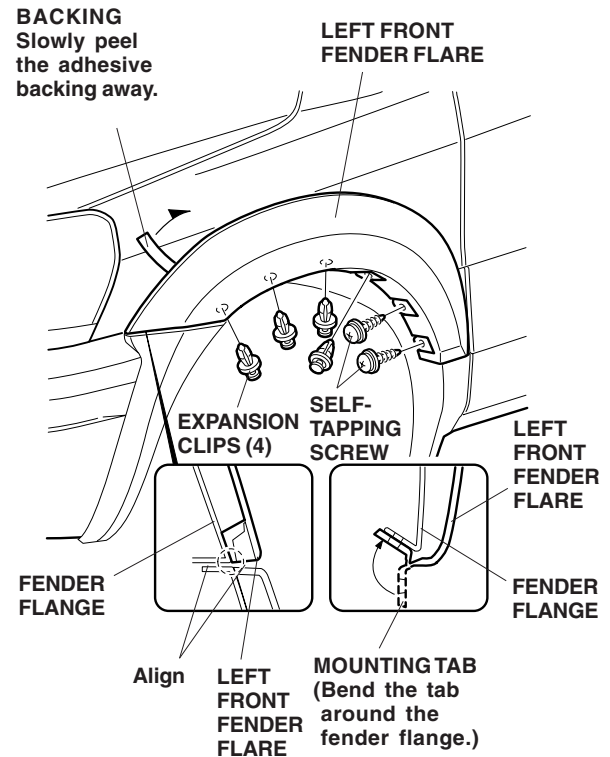

- Install the two self-tapping screws and four expansion clips through the holes in the fender flare and fender flange. Do not tighten the self-tapping screws yet.
- Remove the backings from the fender flare:
 - Start with the front backing.
 - Slowly and carefully peel the backing from the fender flare.
 - After removing the backing, press the fender flare firmly against the fender with the palm of your hand for 30 seconds particularly at the edges. Make sure to apply enough pressure to ensure the adhesive tape sticks to the body.
- Tighten the two self-tapping screws.

Installing the Rear Fender Flare

16. Remove the molding from the inner fender flange.

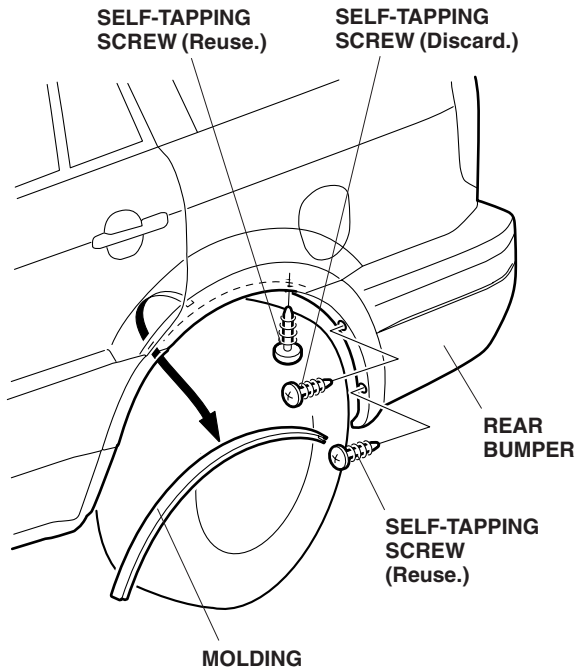

17. Remove the three self-tapping screws that fasten the rear bumper.
18. Remove the six bolts, two expansion clips and one self-tapping screw that secure the inner fender. Rest the inner fender on the rear tire.

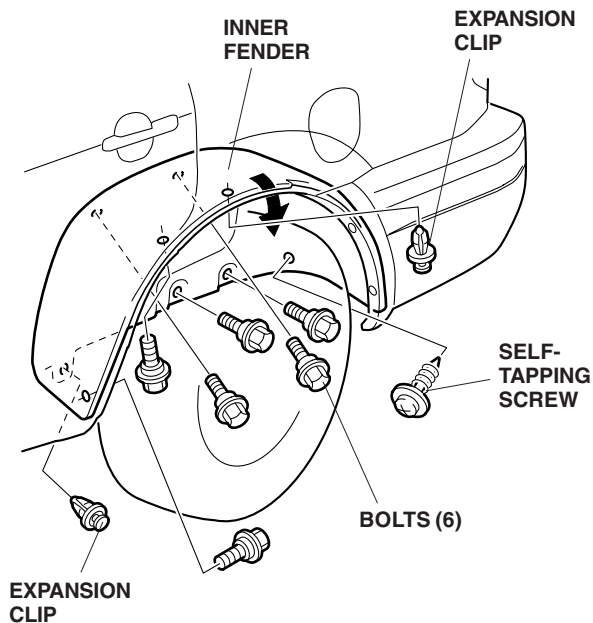

19. Remove the rear fender trim by separating the double-sided tape and pulling the trim down.

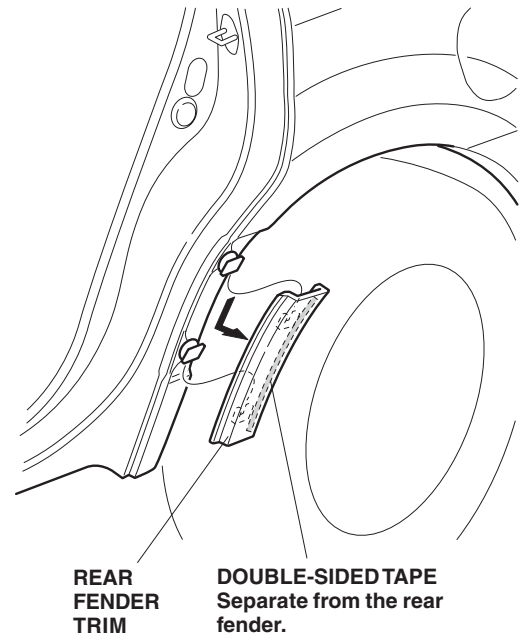

20. Remove and discard the two clips from the rear fender.



21. Using an alcohol pad clean the rear fender where the rear fender flare will attach.
22. On the inside of the left rear fender flare, remove 3 to 5 cm (1 to 2 in.) from each backing. Fold the ends back, and tape them to the front of the fender flare. Remove and discard the front backing.

BACKING
Remove 3 to 5 cm (1 to 2 in.) from the end, and tape it to the front of the fender flare.

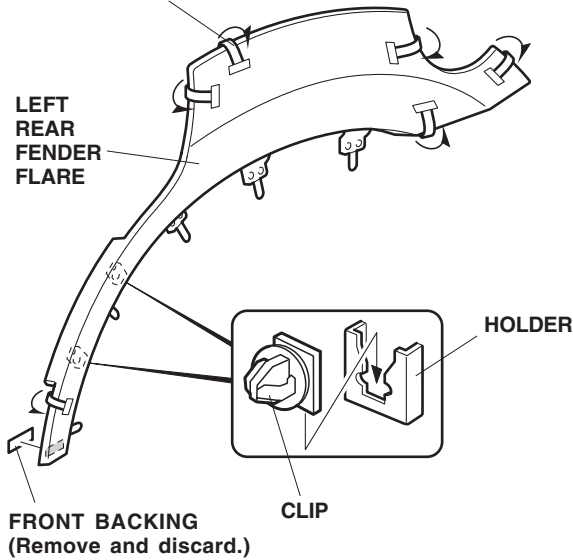

23. Slide one clip into each holder on the rear fender flare.

24. Position the rear fender flare on the rear fender, and align it with the rear ends of the rear fender and fuel door. Bend the mounting tabs around the fender flange.

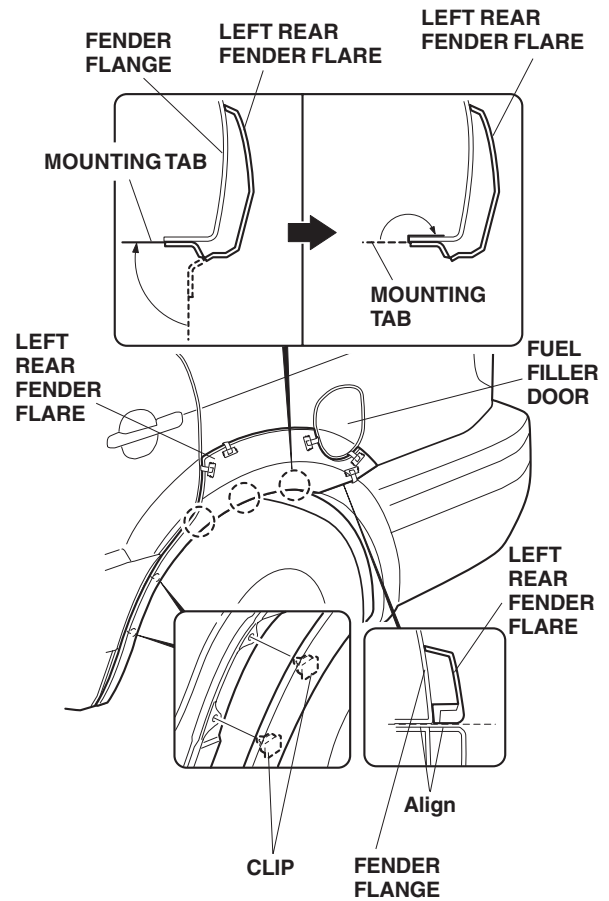

25. Verify that the fender flare clips line up with the holes in the vehicle body, then clip the fender flare into position.
26. Open and close the fuel door to check that it does not interfere with the rear fender flare.

27. Remove the backings from the rear fender flare:

- Slowly and carefully peel the backing from the rear fender flare.
- After removing all of the backings, press the rear fender flare firmly against the fender with the palm of your hand for 30 seconds particularly at the edges. Make sure to apply enough pressure to ensure the adhesive tape sticks to the body.

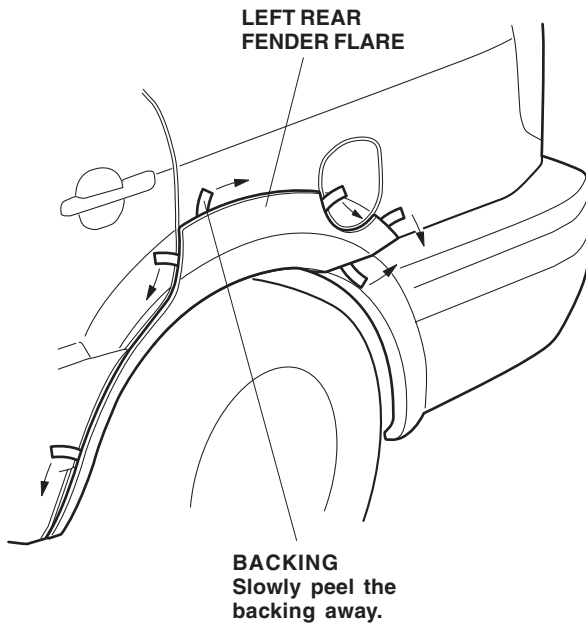

28. Reinstall the inner fender removed in step 18.

29. Reinstall the two self-tapping screws removed in step 17. Do not install the second self-tapping screw from the bottom of the rear bumper at this time.

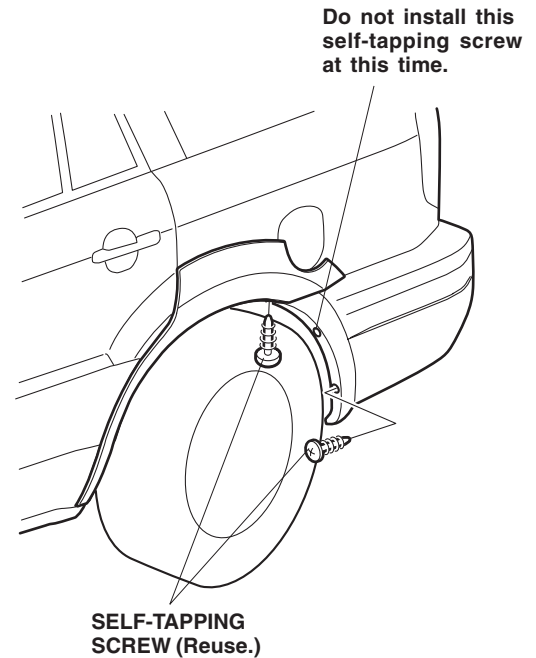

30. Reinstall the molding over the rear fender and fender flange.

Installing the Rear Bumper Flare

31. Using an alcohol pad clean the rear bumper where the rear bumper flare will attach.
32. On the inside of the left rear bumper flare, remove 3 to 5 cm (1 to 2 in.) from each adhesive backing. Fold the ends back, and tape them to the front of the bumper flare.

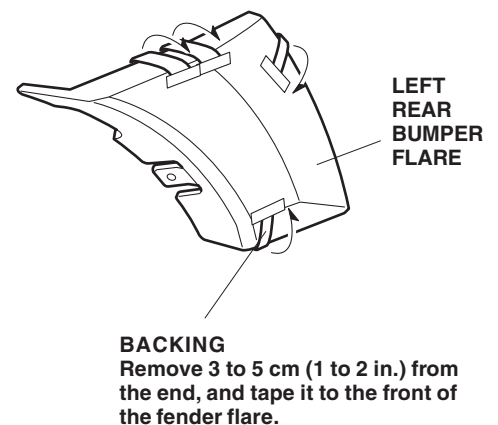

33. Position the rear bumper fender flare on the rear bumper, and align it with the upper edge of the rear bumper. Bend the mounting tabs around the fender flange, then install the self-tapping screw, but do not tighten the screws at this time.

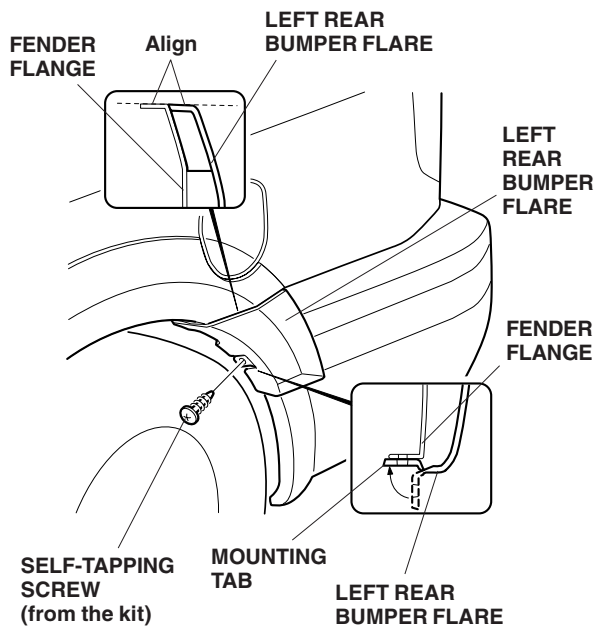

34. Remove the backings from the rear bumper flare:
- Slowly and carefully peel the backing from the rear bumper flare.
 - After removing all of the backings, press the rear bumper flare firmly against the bumper with the palm of your hand for 30 seconds particularly at the edges. Make sure to apply enough pressure to ensure the adhesive tape sticks to the body.

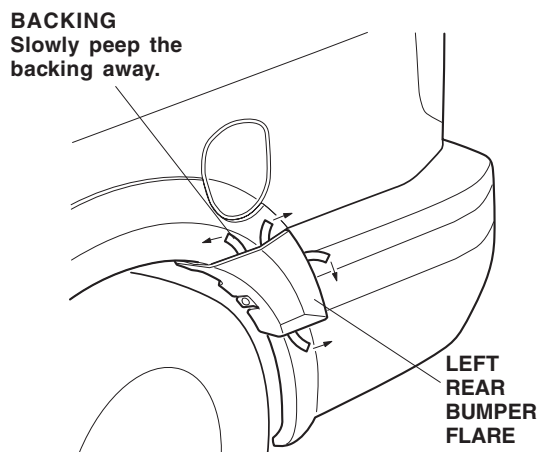

35. Tighten the three self-tapping screws .

Installing the Rear Door Flare

36. Using an alcohol pad clean the door where the rear door flare holder will attach.
37. On the inside of the rear door flare holder, remove 3 to 5 cm (1 to 2 in.) from each backing. Fold the ends back, and tape them to the front of the rear door flare holder. Remove and discard the inner backings.

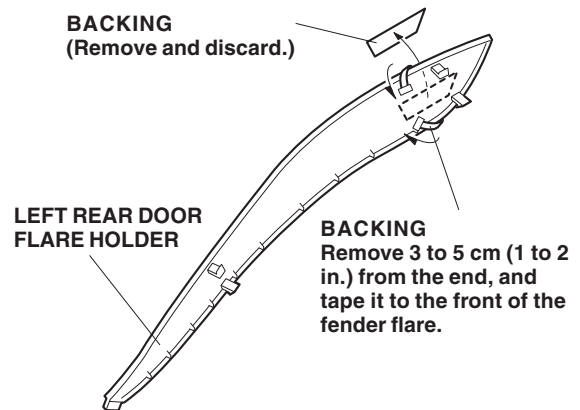

38. Open the left rear door. Position the rear door flare holder on the rear door and align the side edge of the rear door flare holder with the side edge of the rear door. Adjust the rear door flare holder character lines with the character lines of the rear door, then remove the backings from the rear door flare holder.

- Slowly and carefully peel the backing from the rear door flare holder.
- After removing the all of backings, press the rear door flare holder firmly against the rear door with the palm of your hand for 30 seconds particularly at the edges.
- Wear gloves to protect your hands from the tabs on the left rear door flare holder while holding pressure.

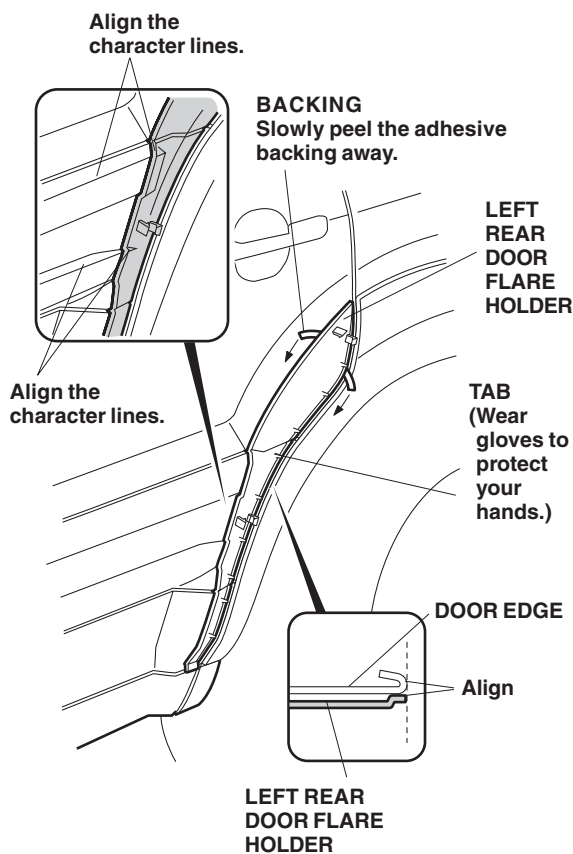

39. Using an alcohol pad clean the door where the rear door flare will attach.

40. On the inside of the rear door flare, remove 1 cm (0.4 in.) from the backings. Fold the ends back, and tape them to the front of the rear door flare.

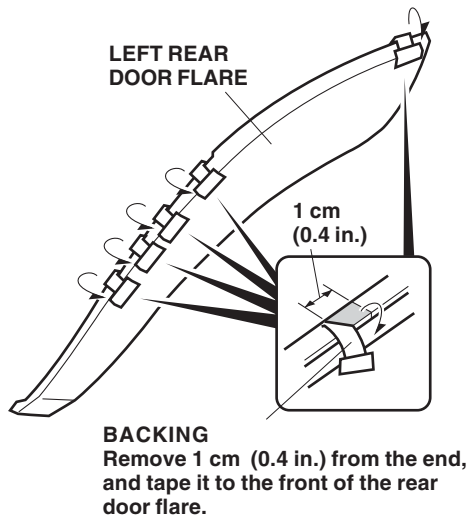

41. Open the left rear door. Insert the tab from the bottom of the left rear door flare holder into the hole in the left rear door flare.
42. Fit each retaining clip on the rear door flare holder into the angled hole in the rear door flare in the order shown. Turn the rear door flare up and make sure the retaining clips from the rear door flare holder line up with the angled hole.

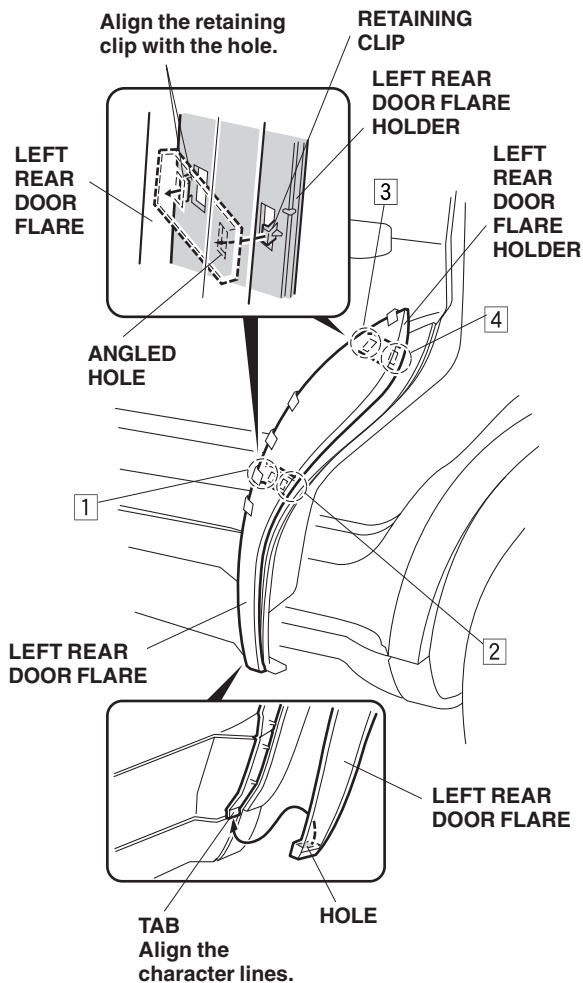

43. Check that the gap between the top edge of the left rear door flare and the left rear door is within 5 mm (0.1 in.).

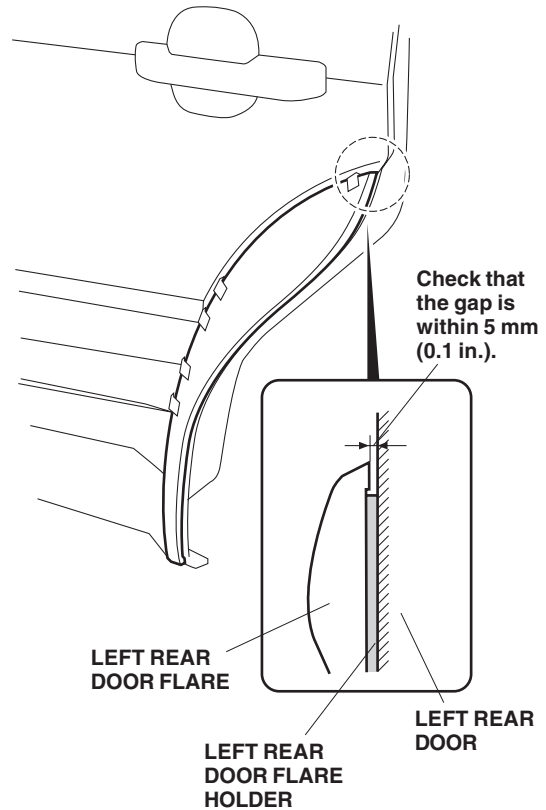

44. If the gap between the top edge of the left rear door flare and the left rear door is more than 5 mm (0.1 mm), repeat steps 41 through 43 to reinstall the left rear door flare.

45. Remove the backings from the rear door flare:
- Slowly and carefully peel the adhesive backing from the rear door flare.
 - After removing the all of adhesive backings, press the rear door flare firmly against the rear door with the palm of your hand for 30 seconds particularly at the edges. Make sure to apply enough pressure to ensure the adhesive tape sticks to the body.

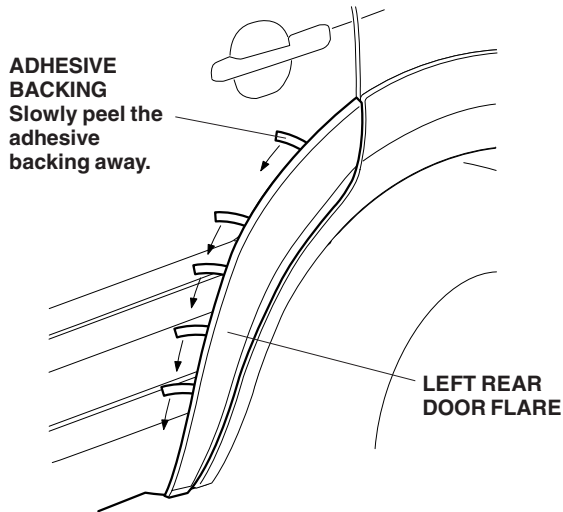

46. Repeat steps 1 through 45 to install the fender flares on the right side of the vehicle.