



INSTALLATION INSTRUCTIONS

Accessory

**SECURITY SYSTEM
P/N 08E50-S5D-100**

Application

2003-2005 CIVIC HYBRID

Publications No.

All 28010

Issue Date

SEP 2004

PARTS LIST

Security unit

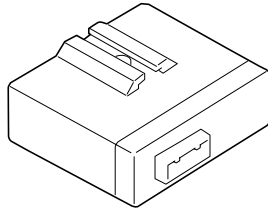

Window decal

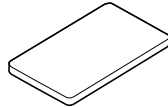

LED

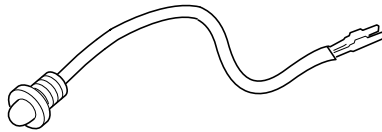

Push nut



Owner's Manual



Bracket

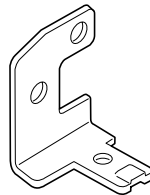

Harness

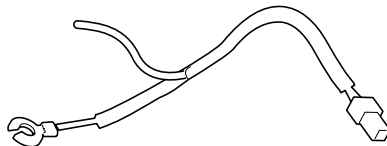

2-Pin connector (for LED)



Fuse, 2A



Fuse label

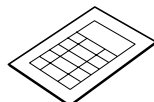

Cushion tape

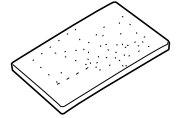

4 Wire ties

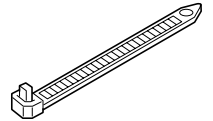

Ground bolt

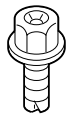

TOOLS AND SUPPLIES REQUIRED

Small flat-tip screwdriver

#2 Phillips screwdriver

Eye protection (face shield, safety goggles, etc.)

Center punch

Drill

5.5 mm Drill bit

File

Felt-tip pen

Ratchet

10 mm Socket

Tape measure

Diagonal cutters

Illustration of the Security System Installed on the Vehicle

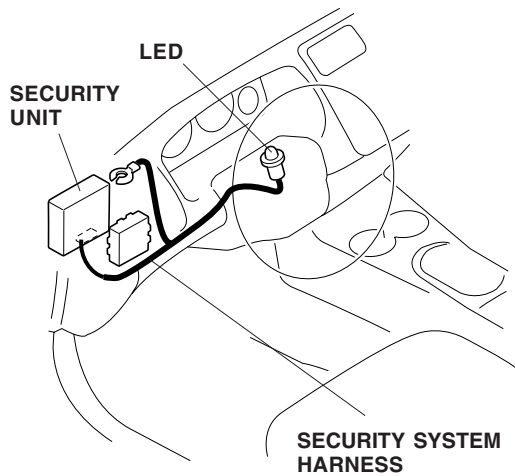

INSTALLATION

Customer Information: The information in this installation instruction is intended for use only by skilled technicians who have the proper tools, equipment, and training to correctly and safely add equipment to your vehicle. These procedures should not be attempted by "do-it-yourselfers."

1. Make sure you have the anti-theft code for the radio, then write down the radio station presets.
2. Disconnect the negative cable from the battery.
3. Remove the dashboard lower cover on the driver's side of the vehicle. Turn the two knobs counterclockwise, and release the four retaining tabs.

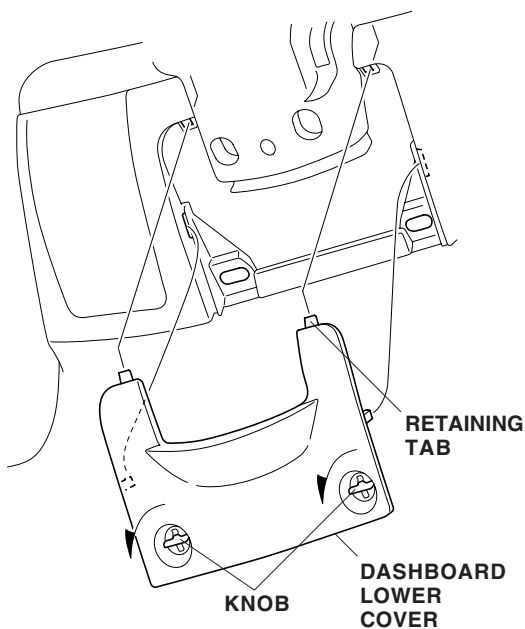

4. Remove the driver's dashboard under cover. Turn the knobs counterclockwise, and release the two clips and one retaining tab.

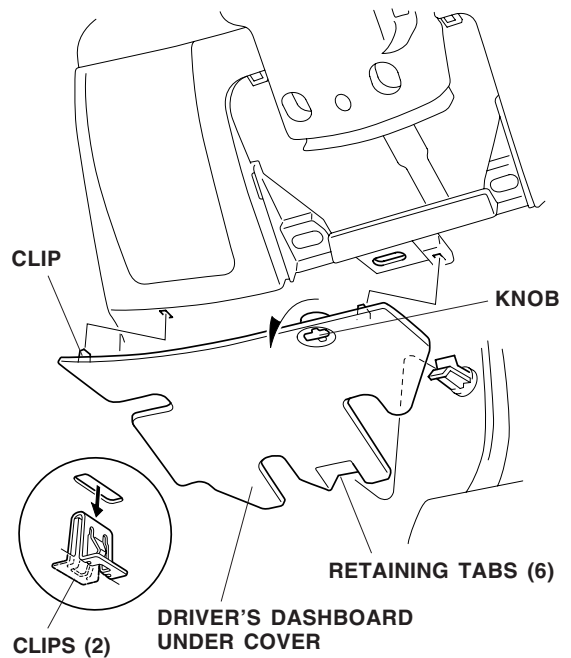

5. Remove the upper steering column cover (two self-tapping screws, one washer-screw and six retaining tabs).

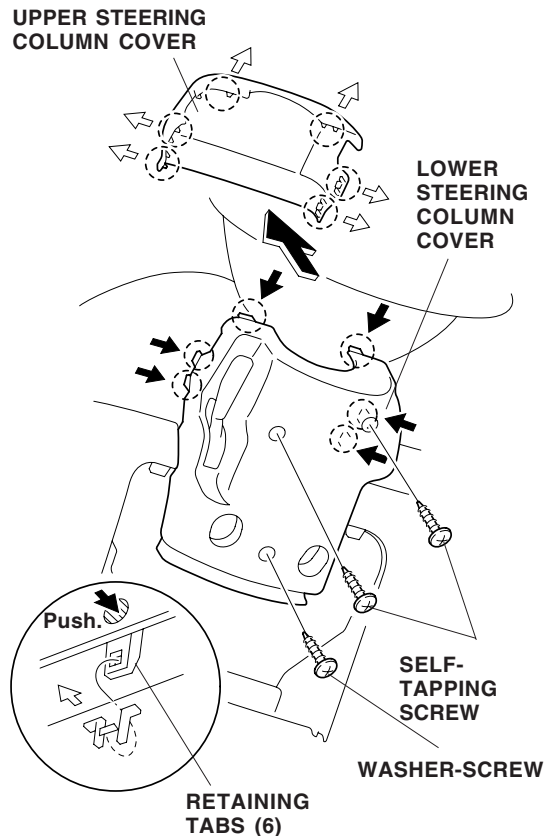

Installing the LED

6. Measure and mark the inside of the upper steering column cover.

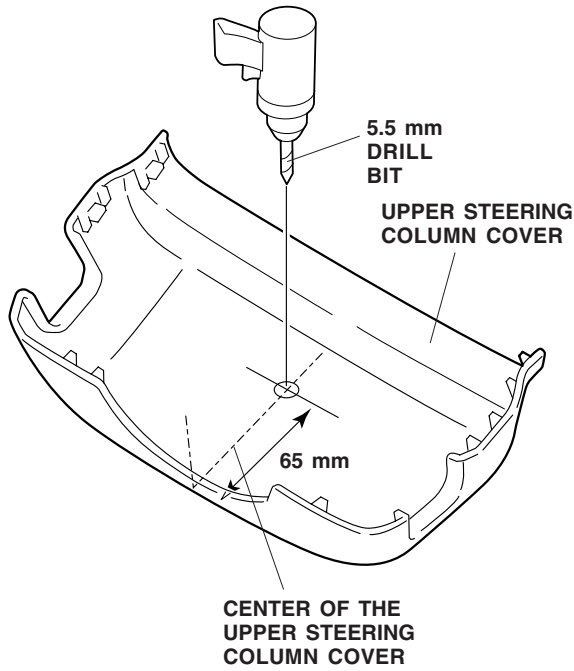

7. While wearing eye protection, lightly center-punch the mark, and drill a 5.5 mm hole through the center-punched mark. Remove all burrs with a file.

8. Route the terminal ends of the LED through the hole you just drilled, and secure the LED with the push nut. Install the push nut securely.

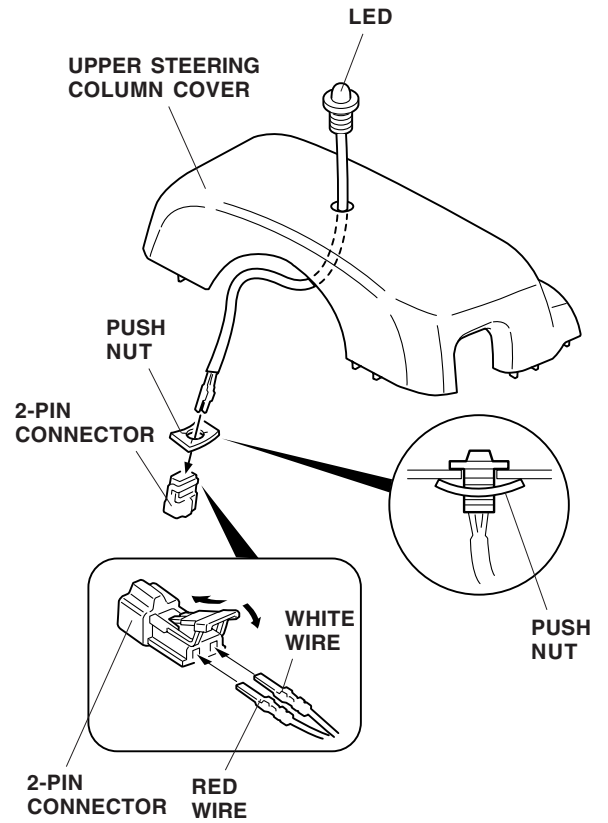

9. Get the 2-pin connector from the kit. Firmly push the LED terminals into the 2-pin connector until they click into position, then lower the lock.

10. Install the bracket onto the security unit.

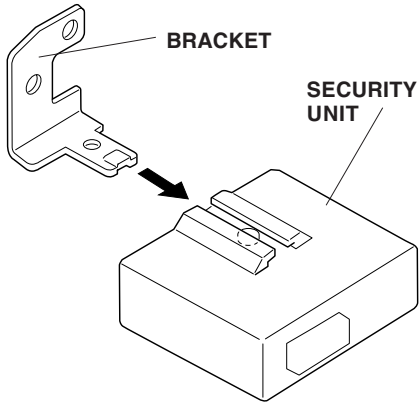

11. On the left side of the steering column bracket, remove and discard the bolt that secures the cruise control unit to the steering column bracket.

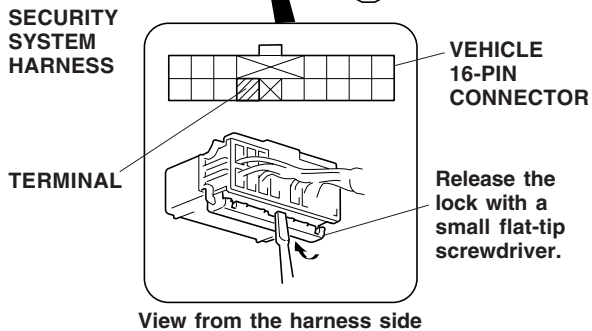
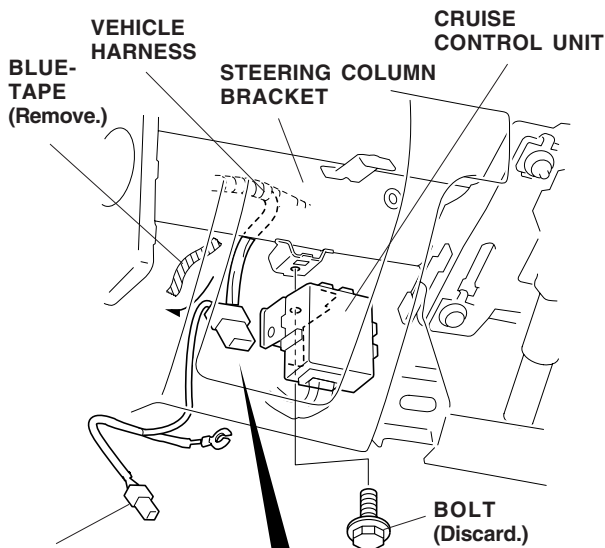

12. Behind the steering column bracket, locate the 16-pin connector blue-taped to the vehicle harness. Remove the tape to free the connector, and pull down the 16-pin connector.

13. On the back of the 16-pin connector, use a small flat-tip screwdriver to release the lock. Insert the terminal from the security system harness into the 16-pin connector in the location shown. Reattach the lock to the connector.

14. Attach the cruise control unit, the security unit, and the ground terminal to the steering column bracket using the ground bolt supplied.

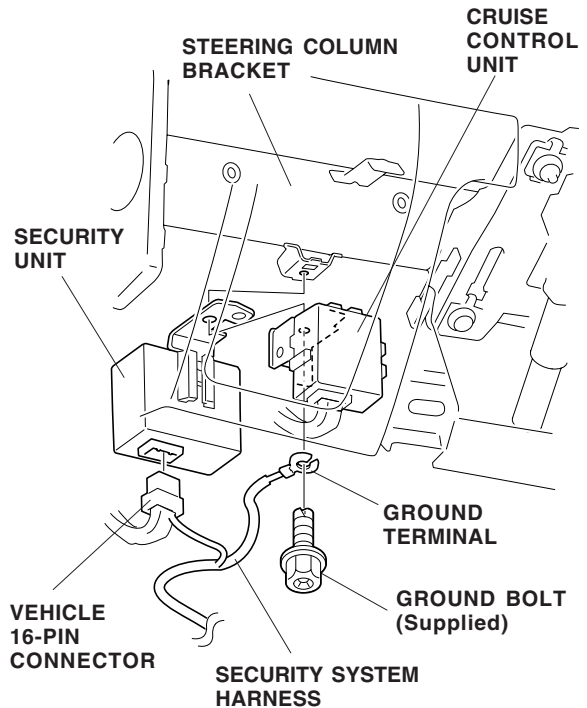

15. Plug the vehicle 16-pin connector (freed in step 12) into the security unit.

16. Position the upper steering column cover above the steering column, and route the 2-pin connector of the harness under the steering shaft. Plug the 2-pin connector from the LED into the security system harness 2-pin connector, and wrap the cushion tape around the connectors.

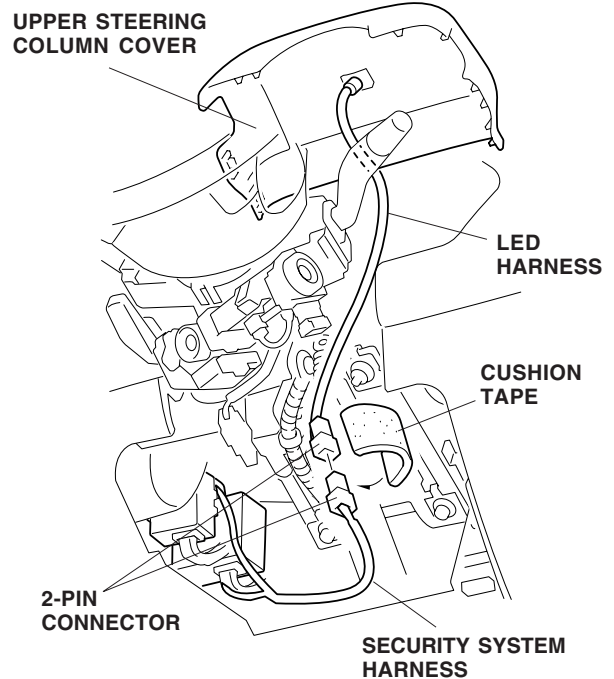

- Secure the LED harness to the vehicle harness with four wire ties in the areas shown. Cut the excess off of the wire ties.

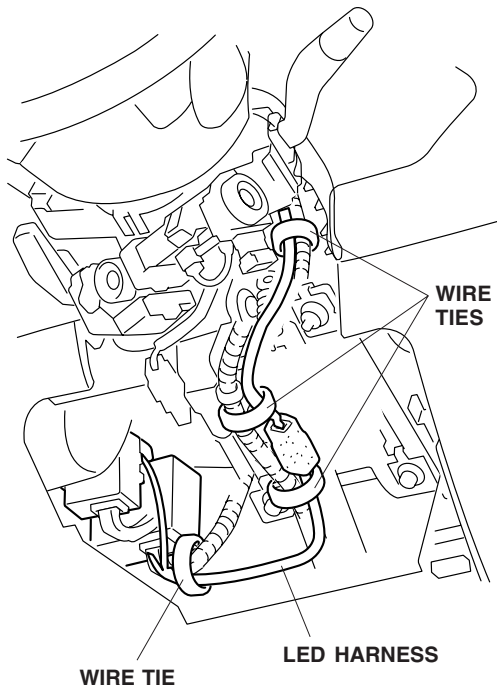

- Install the fuse (2A) provided into the No.15 slot of the fuse box.

NOTE: The No. 15 slot with the new 2 amp fuse controls the memory for the security system. In some vehicles, you may find a higher amp fuse already installed in the No. 15 slot. That fuse serves no purpose for this vehicle; remove it.

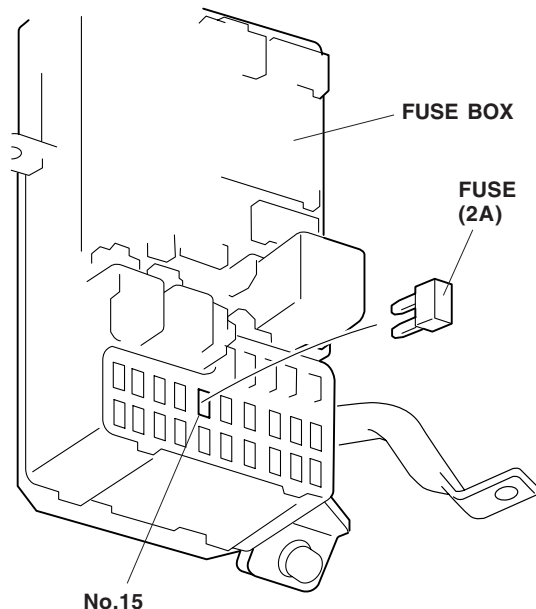

- Attach the fuse label "OPTION FUSE (2A)" over the No.15 on the back of the dashboard lower cover.

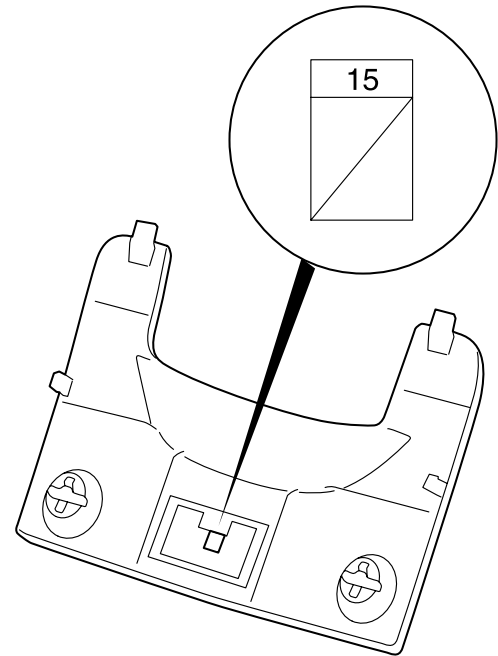

- Check that all wire harnesses are routed properly and all connectors are plugged in.
- Reinstall all removed parts.
- Reconnect the negative cable to the battery, and reset the radio station presets.
- Reset the clock
- Check the operation of the security system as described in the Owner's Manual supplied.
- Do the ECU idle learn procedure.
 - Make sure all electrical items are turned off.
 - Start the engine. Hold the engine speed at 3,000 rpm with no load (in Park or Neutral) until the radiator fan comes on.
 - Let the engine idle for about 5 minutes with the throttle fully closed and with all electrical items off.

NOTE: If the radiator fan comes on during this step, the time it operates must not be included in the 5 minutes.

NOTE: When the battery terminals are disconnected: "Remaining Capacity of the IMA Battery" is not indicated when the engine is started. It will be indicated after driving for about 30 minutes. At that time, "regeneration" will be lowered temporarily, but this is normal.