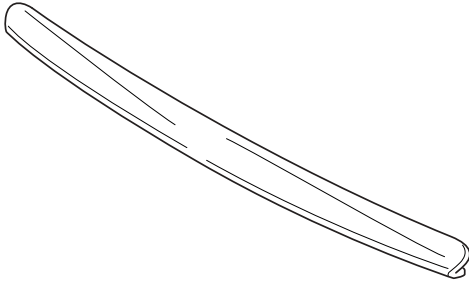

PARTS LIST

Gold hood molding

**TOOLS AND SUPPLIES REQUIRED**

10 mm Socket
Ratchet
Long flat-tip screwdriver
Masking tape
Shop towel

INSTALLATION**NOTE:**

Be careful not to damage the body paint finish when install the gold hood molding.

1. Open the hood and remove the four cap nuts securing the hood molding.

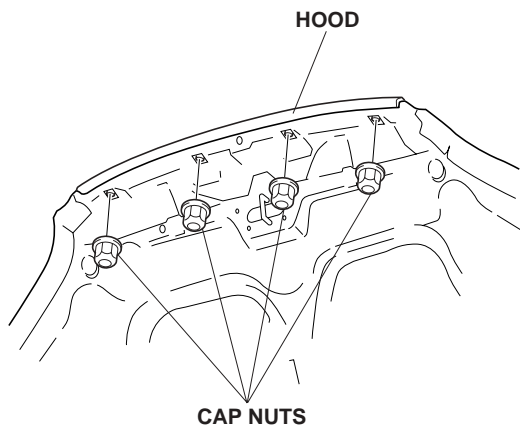

2. Close the hood. To prevent damage to the body, apply masking tape to the left of the hood in the area shown.

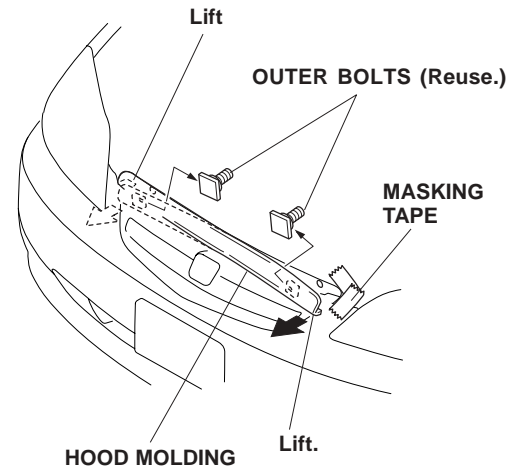

3. Lift the both ends of the molding and remove the two outer bolts from the molding. Release the ends.
4. Again lift the right end of the molding and remove the bolt next to the right outer bolt by sliding it toward the left with the end of a flat-tip screwdriver. To prevent damage to the body, use a shop towel around the end of the screwdriver.

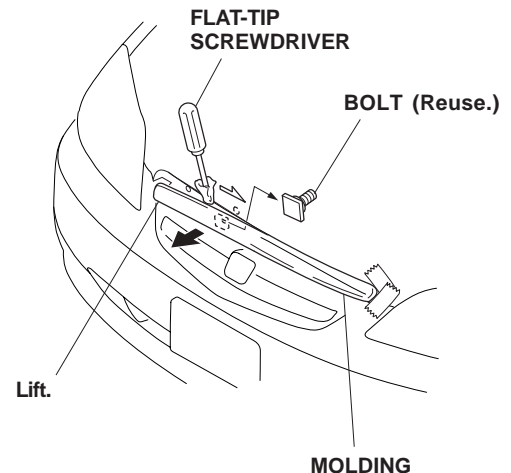

- Remove the hood molding from the hood by sliding it toward the left.

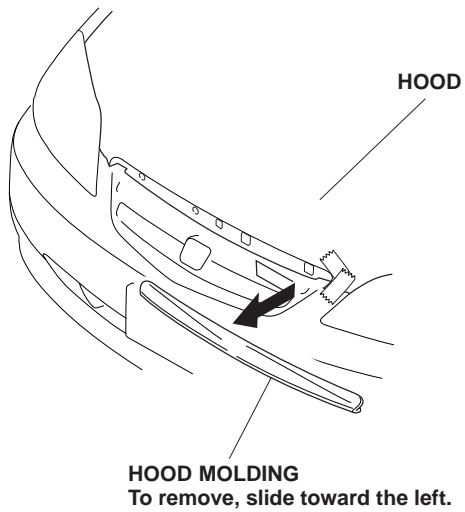

- Remove the remaining bolt (next to the left outer bolt).
- Using a flat-tip screwdriver, release the upper retaining tab of the center clip.

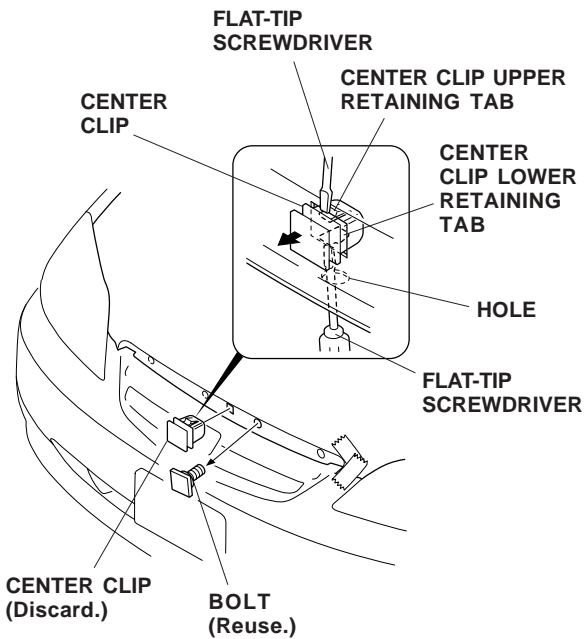

- Open the hood. Reach through the center hole in the back of the hood, release the lower retaining tab of the center clip and remove the clip from the hood.

- Slide the four bolts into place on the gold hood molding.

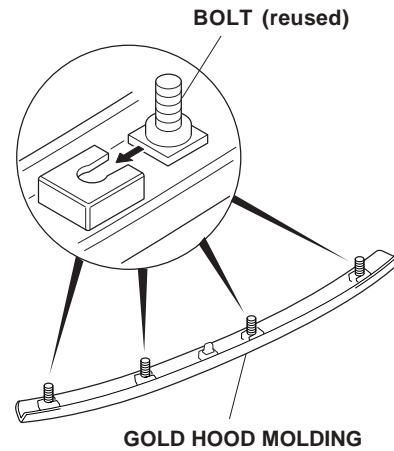

- Fit the gold hood molding into place on the hood and install a cap nut on the end of each bolt. Torque the cap nuts to 5 N·m (4 lb-ft).

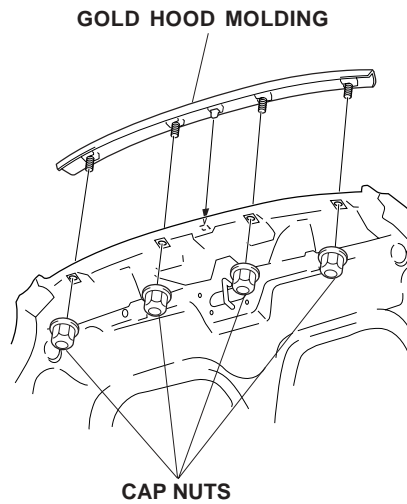

- Remove the masking tape.