



INSTALLATION INSTRUCTIONS

Accessory

TRAILER HITCH

Application

2003-2004 ELEMENT

Publications No.

All 24318

Issue Date

DEC 2002

PARTS LIST

Trailer Hitch Kit
P/N 08L92-SCV-100

Trailer hitch

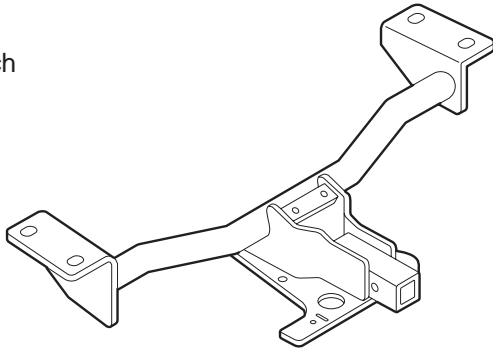

Left stay

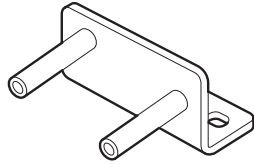

Right stay

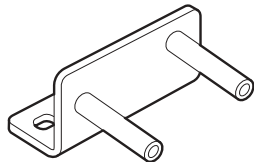

4 Side plates



Ball mount

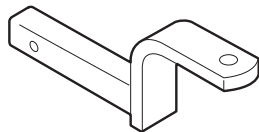

4 Bolts, 12 x 135 mm



4 Bolts, 12 x 35 mm

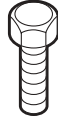

U-bolt

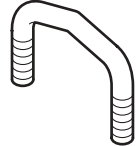

2 Nuts, 8 mm



2 Washers, 8 mm



2 Spring washers, 8 mm



8 Nuts, 12 mm



12 Washers, 12 mm



8 Spring washers, 12 mm



Retaining pin

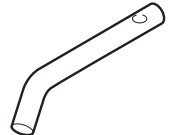

Retaining pin clip



Receiver cover

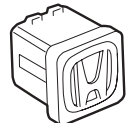

**Harness Kit (sold separately)
P/N 08L91-SCV-100**

Trailer harness

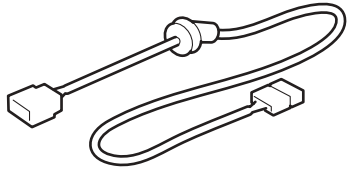

Trailer unit harness

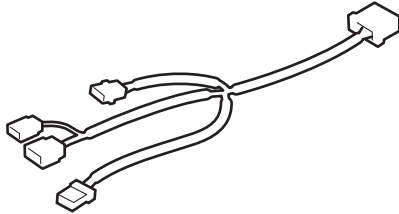

Trailer unit

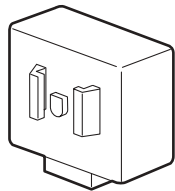

Connector bracket

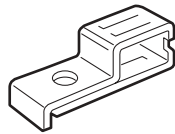

Unit bracket

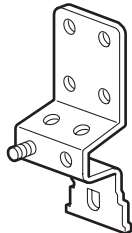

2 Flange nuts



Flange bolt

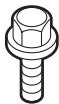

8 Wire ties

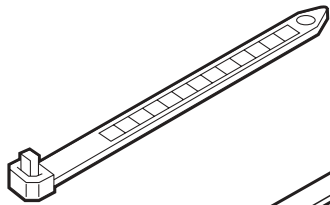

3 Wire ties with clip

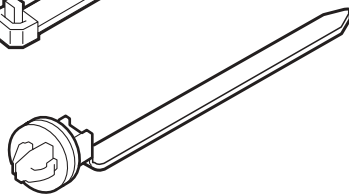

Connector clip

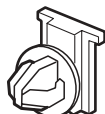

Fuse label A

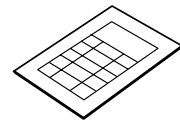

Fuse label B



5 EPT sealers

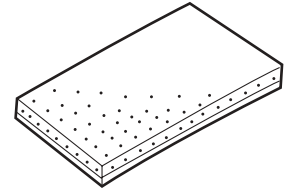

Fuse, 7.5A



Owner's Manual

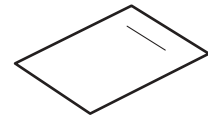

TOOLS AND SUPPLIES REQUIRED

Phillips screwdriver

Flat-tip screwdriver

10mm, 13mm, 14mm, and 19mm Combination wrenches

Torque wrench

Tape measure

Diagonal cutters

Piece of steel wire

Isopropyl alcohol

Shop towel

Cardboard or blanket

12 mm T-wrench

Clip remover

Utility knife

INSTALLATION

Customer information: The information in this installation instruction is intended for use only by skilled technicians who have the proper tools, equipment, and training to correctly and safely add equipment to your vehicle. These procedures should not be attempted by “do-it-yourselfers.”

1. Make sure you have the anti-theft code for the radio, then write down the frequencies for the preset buttons.
2. Disconnect the negative cable from the battery.

Routing the Trailer Harness

If equipped, remove the splash guards.

3. Remove the rear bumper (four self-tapping screws, two bolts, two clips).

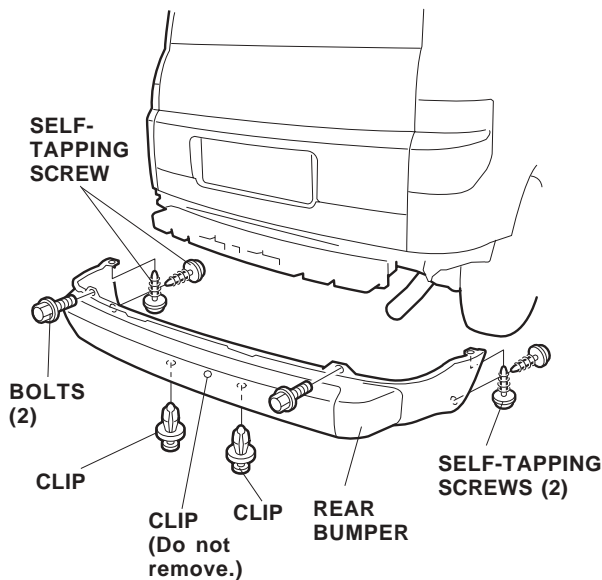

4. Open the hatch and the tailgate and take out the cargo area floor (two hooks).

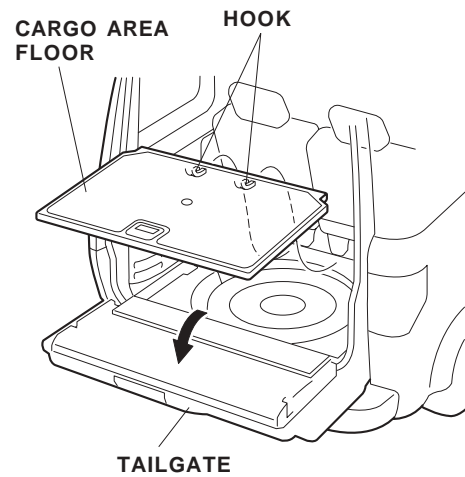

5. Raise the tailgate lower trim and remove the three self-tapping screws that fasten the tailgate lower trim. Remove the lower trim (two clips).

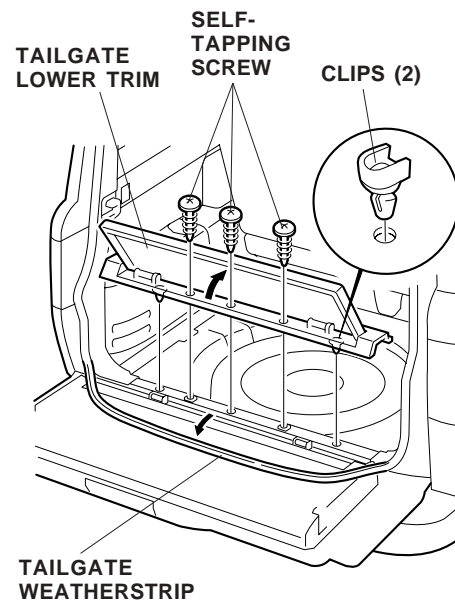

6. Remove the tailgate weatherstrip from the area shown.

- Pull up on the reclining strap to tilt the right rear seat-back down, then remove the right rear seat side cover by pulling the hook in the direction shown to release the two upper hooks and four tabs.

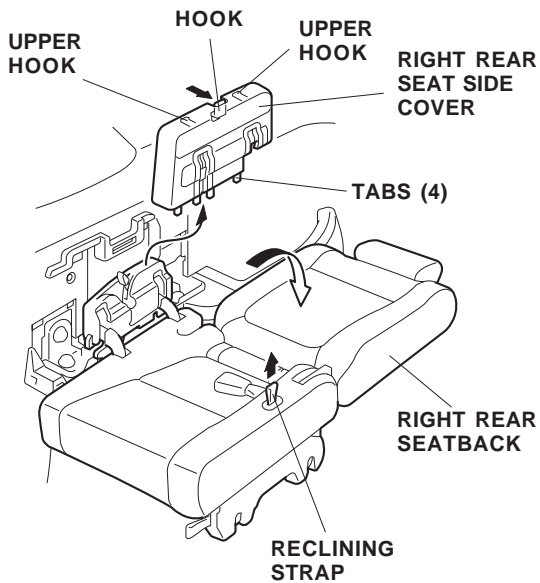

- Unlock the right rear seat by pulling the right rear seat foot lock release strap out.

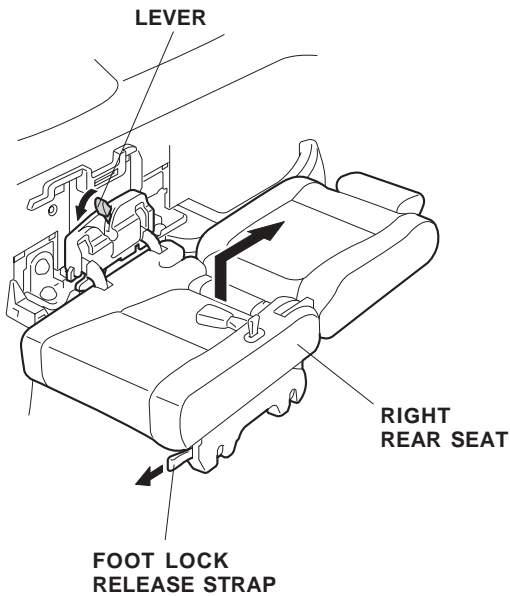

- Push the lever in the direction shown, then remove the right rear seat by lifting the rear of the seat and sliding the seat through the rear of the vehicle.

- Slide the passenger's seat all the way forward.

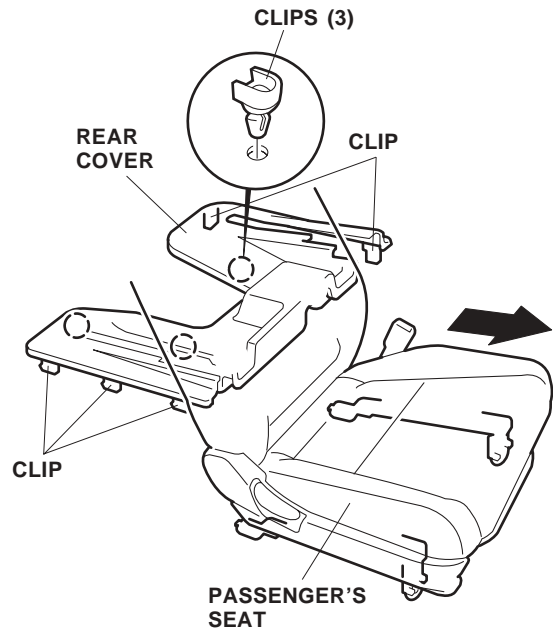

- Behind the passenger's seat, remove the eight clips that secure the rear cover to the vehicle panel and remove the cover. Take care not to damage the clips.

- Remove the right side sill trim (ten clips and two retaining tabs). Take care not to damage the clips and retaining tabs.

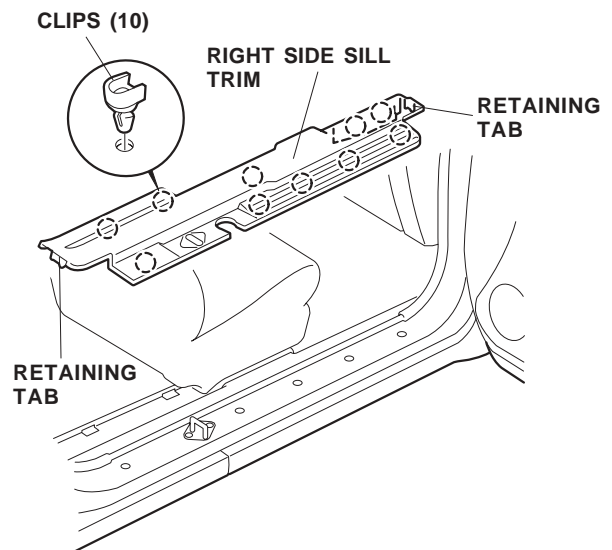

- Remove the two tie-down hooks from the right rear side trim panel (one screw for each).

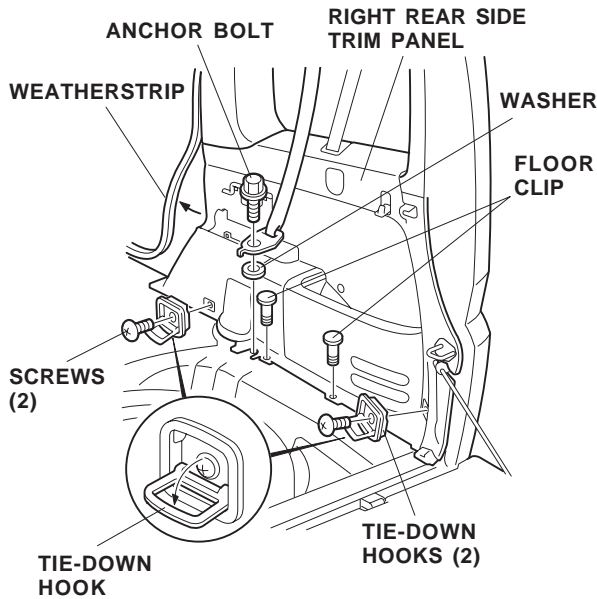

- Remove the two floor clips and weatherstrip in the area shown.
- Remove the anchor bolt and washer that fasten the seat belt.
- Open the plastic covers and remove the self-tapping screws concealed under the covers. Open the cargo net hook plastic cover and remove the self-tapping screw concealed under the hook. Remove the self-tapping screw just behind the cargo net hook.

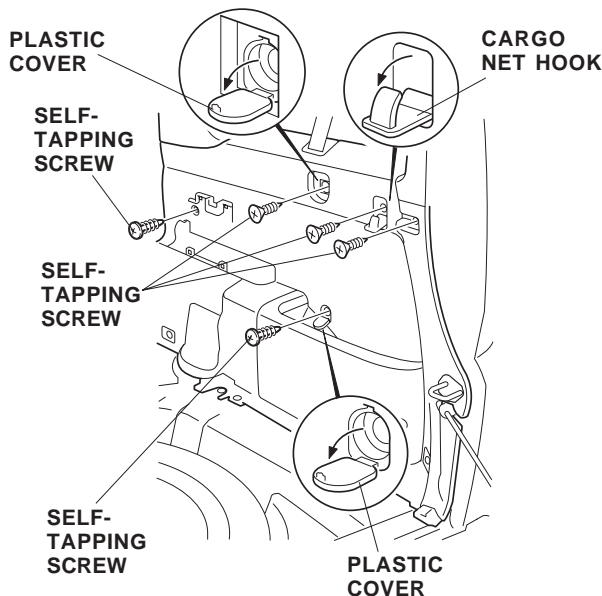

- Remove the right rear strut cover from the right rear side trim panel (eight retaining tabs).

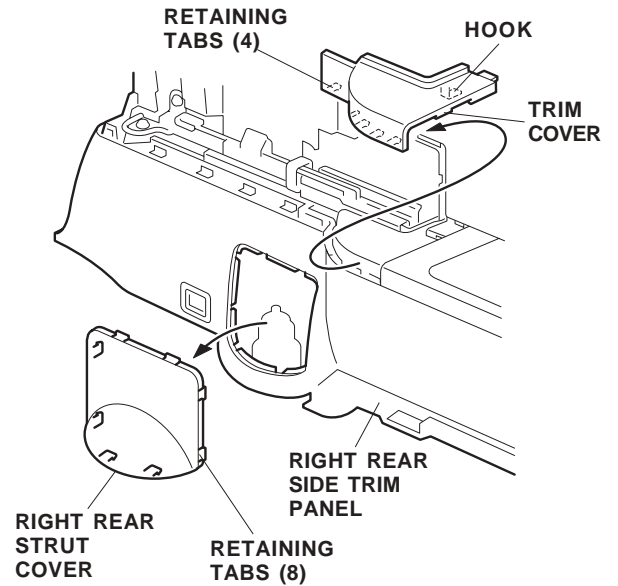

- Remove the trim cover (four retaining tabs and one hook).
- Remove the hinge bracket on the right rear side trim panel (two bolts and one flange nut).

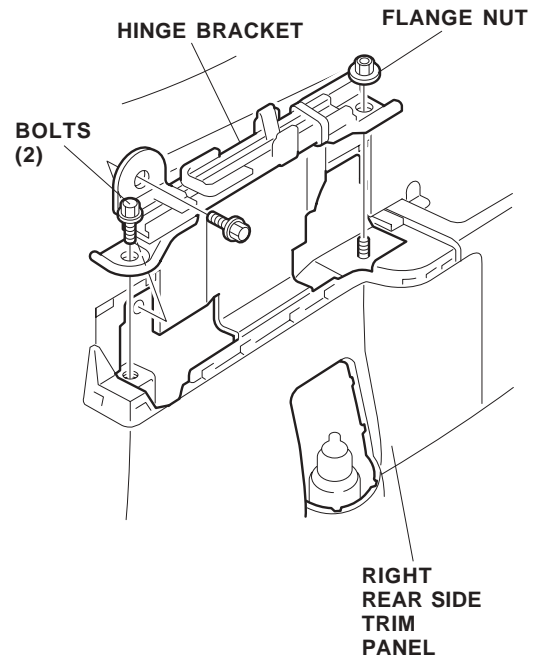

20. Remove the seat belt cover (two retaining tabs and two hooks), then remove the right rear side trim panel by pulling it out toward you (six clips and six retaining tabs).

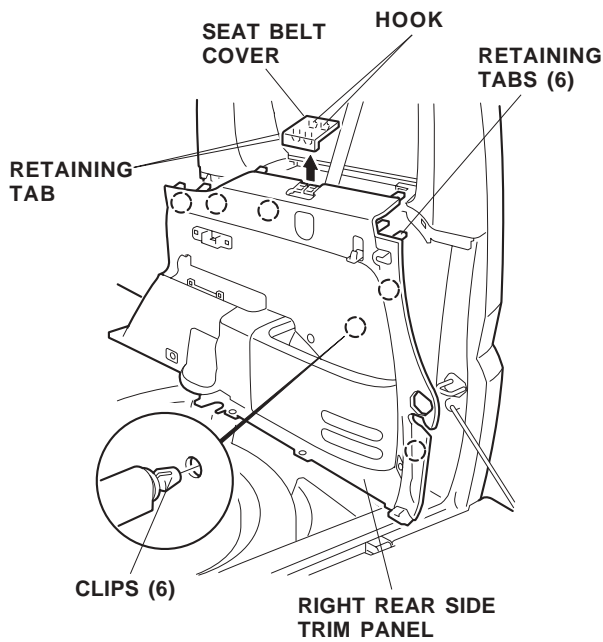

21. Slide the trailer unit onto the unit bracket. Do not push on the connector area of the trailer unit. Plug the trailer unit harness 12-pin connector into the trailer unit.

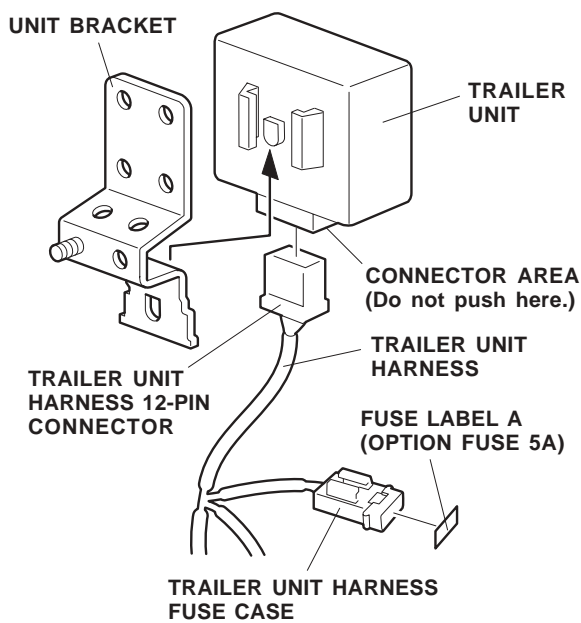

22. Attach the fuse label A (OPTION FUSE 5A) to the fuse case of the trailer unit harness.

23. Remove the plastic cover from the right rear inner panel.

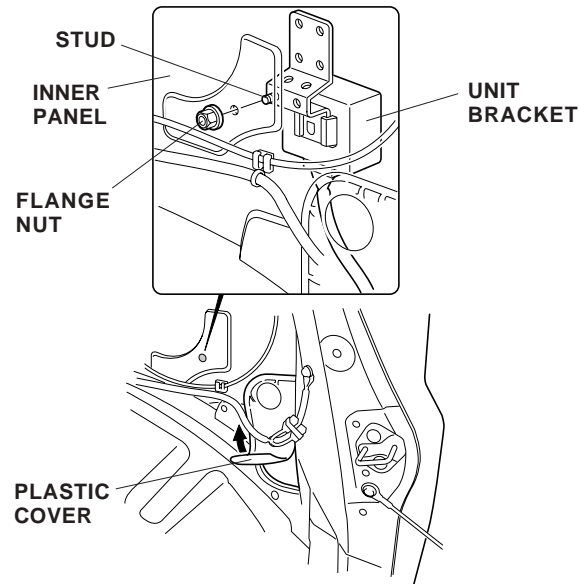

24. Position the unit bracket behind the inner panel, and insert the stud from the unit bracket into the hole in the inner panel. Install the flange nut on the end of the stud, and tighten the flange nut securely.
25. Route the trailer unit harness 2-pin connector, 6-pin connector, and fuse case out from the upper hole.

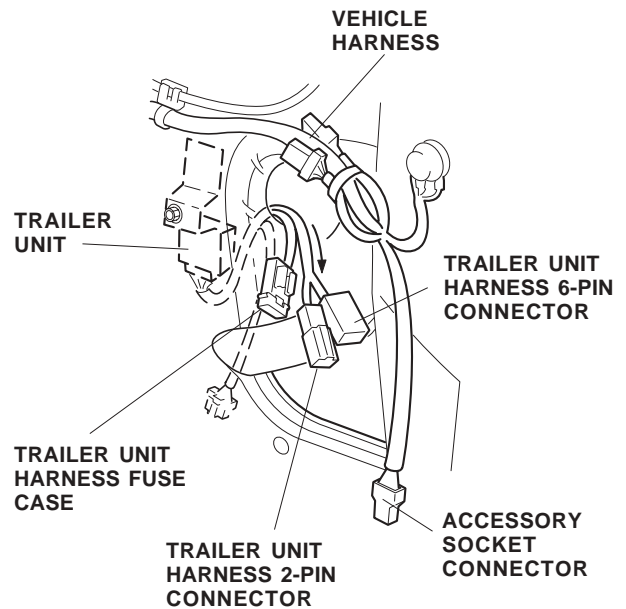

26. Locate the 6-pin and 2-pin connectors blue-taped to the vehicle harness. Plug the 6-pin and 2-pin connectors into the 6-pin and 2-pin connectors of the trailer unit harness.

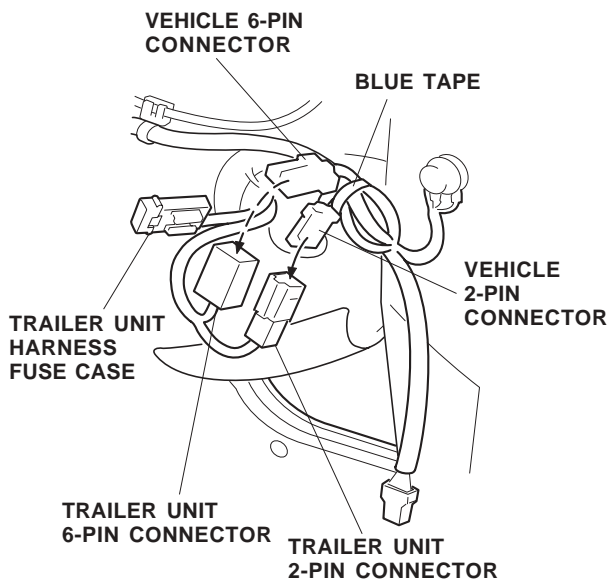

27. Secure the trailer unit harness fuse case to the trailer unit harness with a wire tie.

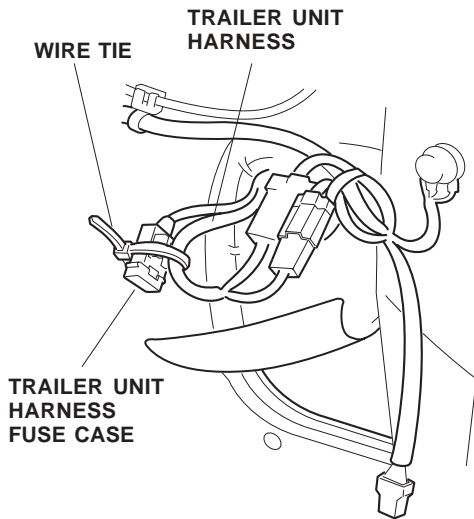

28. Route the trailer unit harness 4-pin connector out the bottom of the cover opening.
29. Push the trailer unit harness connectors into the hole in the plastic cover.
30. Reinstall the plastic hole cover.

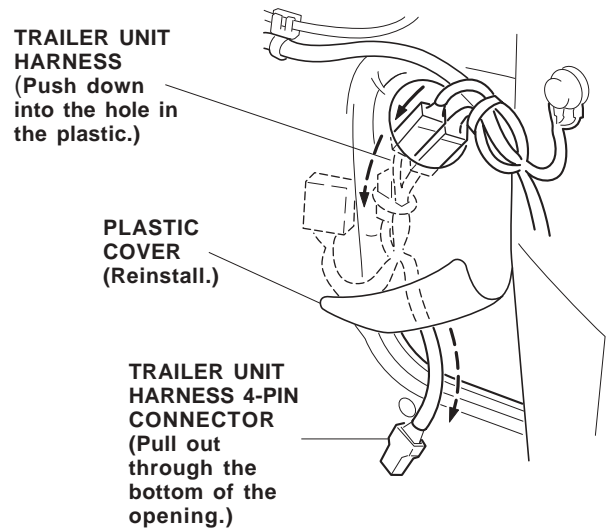

31. Attach the wire tie with clip to the trailer unit harness 220 mm away from the grommet. Using diagonal cutters, clip off the excess length of the wire tie.

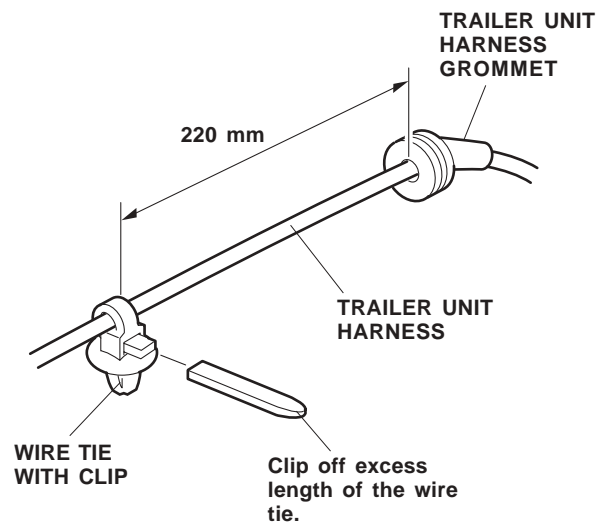

32. Attach the two EPT sealers to the trailer unit harness between the wire tie with clip and grommet in the area shown.

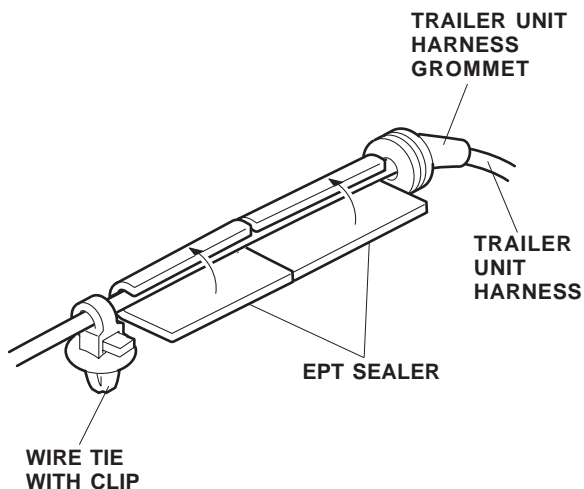

33. Locate the plastic cover at the edge of the tailgate near the spare tire. Cut the plastic cover with a utility knife with cross-cuts, as shown.

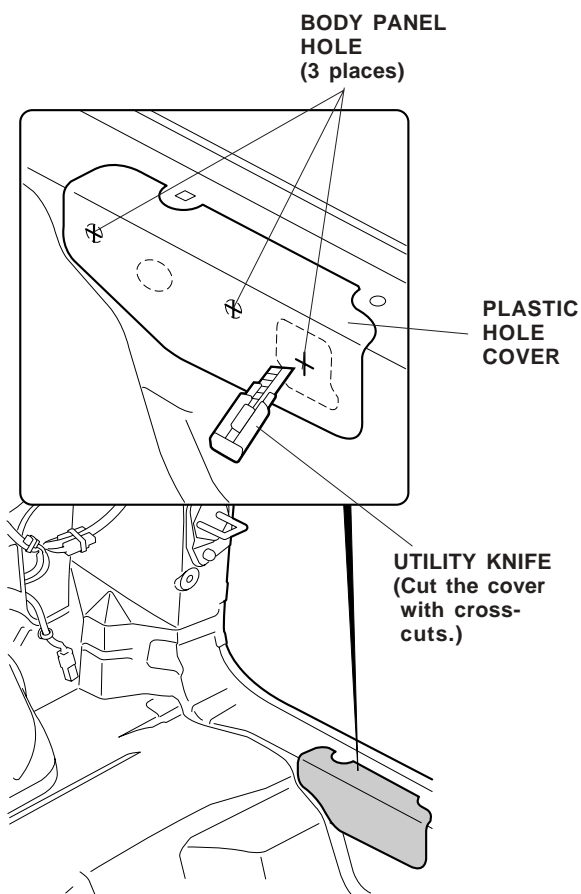

34. With the tailgate closed, locate and remove the large grommet from the right rear side of the tailgate panel.

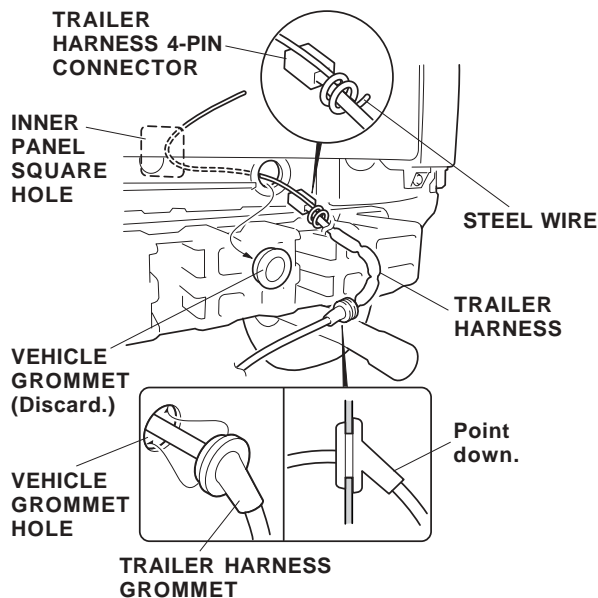

35. Attach a piece of steel wire to the trailer harness 4-pin connector, and route the 4-pin connector through the vehicle grommet hole and through the large hole you just cut in the plastic cover. Seat the trailer harness grommet in the vehicle grommet hole with the end facing down.
36. Inside the right rear of the vehicle, route the trailer unit harness 4-pin along the rear of the vehicle, and toward the trailer unit harness. Plug the trailer harness into the 4-pin connector.

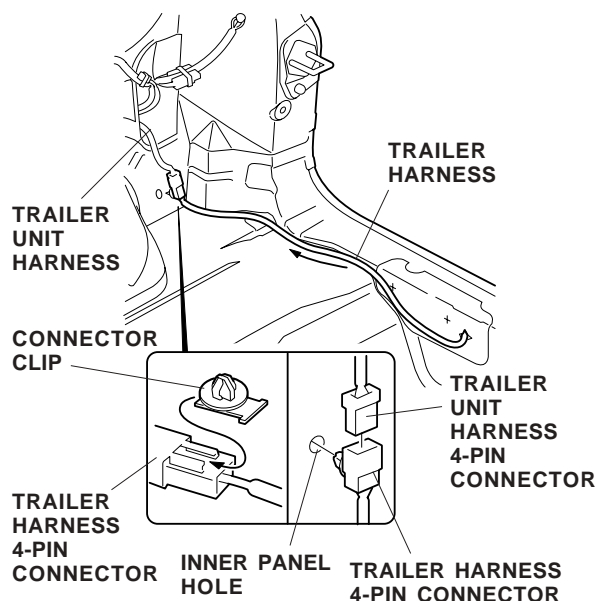

37. Slide the connector clip onto the trailer harness 4-pin connector and push the clip into the hole in the inner panel.

38. Secure the trailer harness:

- Push the wire tie with clip attached to the trailer harness in step 31 into the hole in the inner body panel.
- Attach another wire tie with clip to the trailer harness, and push the wire tie with clip into the outer body panel hole.
- Using isopropyl alcohol, thoroughly clean the area where the two EPT sealers will attach. Secure the trailer harness to the body panel with the two EPT sealers in the areas shown. Do not allow any slack in the trailer harness when installing the wire tie with clip and the EPT sealer.

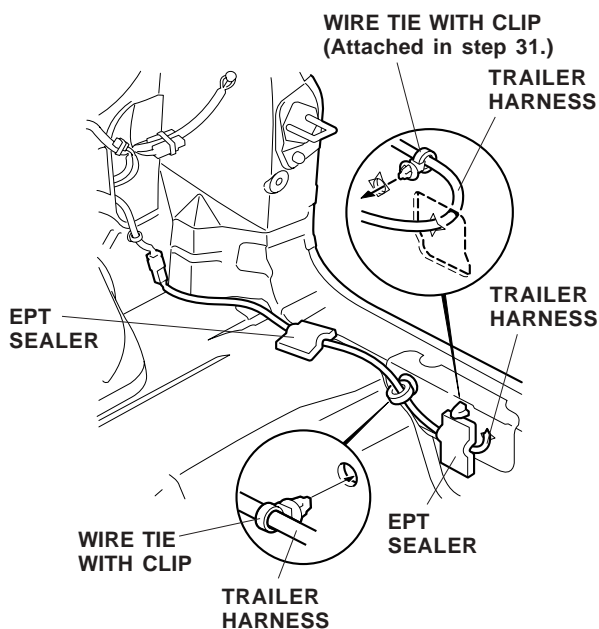

39. Hang the trailer harness down through the clearance between the rear bumper beam and body panel. Reinstall the rear bumper.

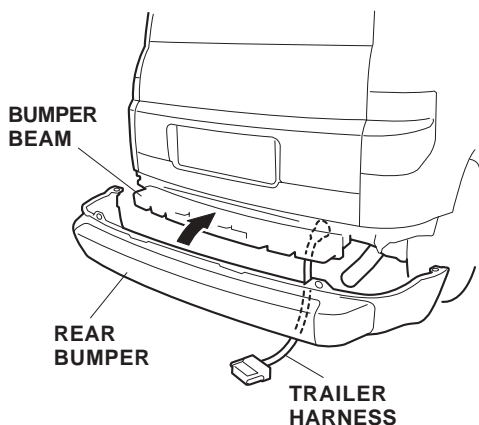

40. In the engine compartment, remove the cover from the under-hood fuse/relay box and install the fuse (7.5A) in the relay box.

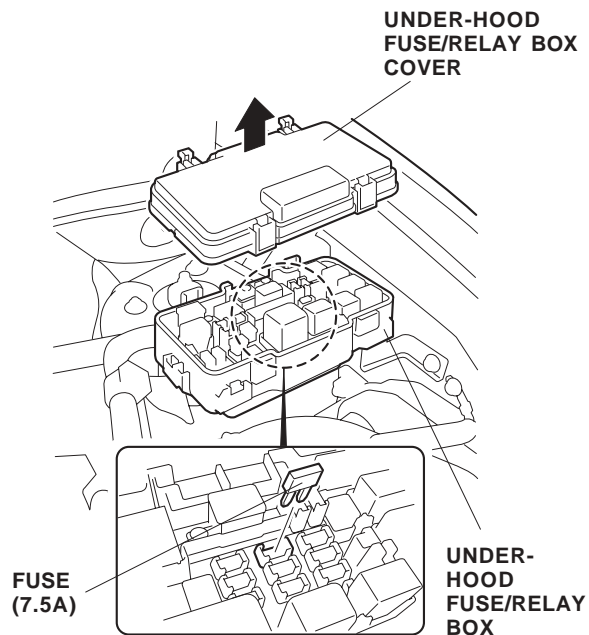

41. Attach the fuse label B (7.5A) to the relay box cover in the area shown. Reinstall the relay box cover.

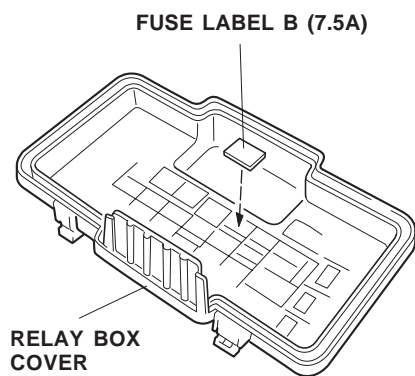

Installing the Trailer Hitch

42. Slide the four 12 x 135 mm bolts into the right and left stays.

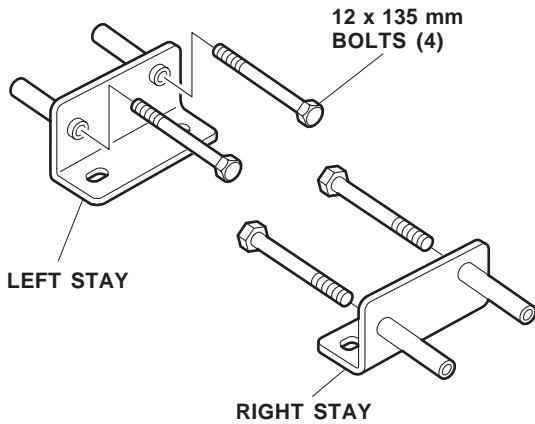

43. From the inboard side of the vehicle frame, slide the right and left stays into the right and left rear frame rails.

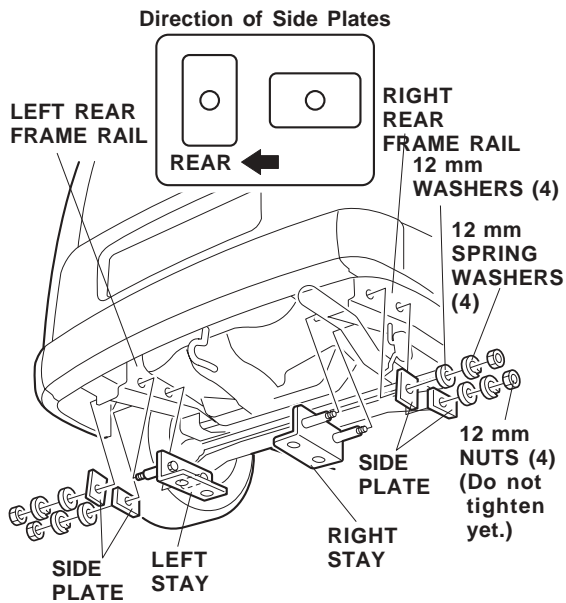

44. From the outboard side, slide the side plates onto the 12 x 135 mm bolts in the direction shown, then install the four 12 mm washers, four 12 mm spring washers and four 12 mm nuts on the ends of the 12 x 135 mm bolts. Do not tighten the nuts yet.

45. With the help of an assistant, position the trailer hitch on the right and left stays and align the holes. Install the four 12 x 35 mm bolts, eight 12 mm washers, four 12 mm spring washers and four 12 mm nuts. Do not tighten yet.

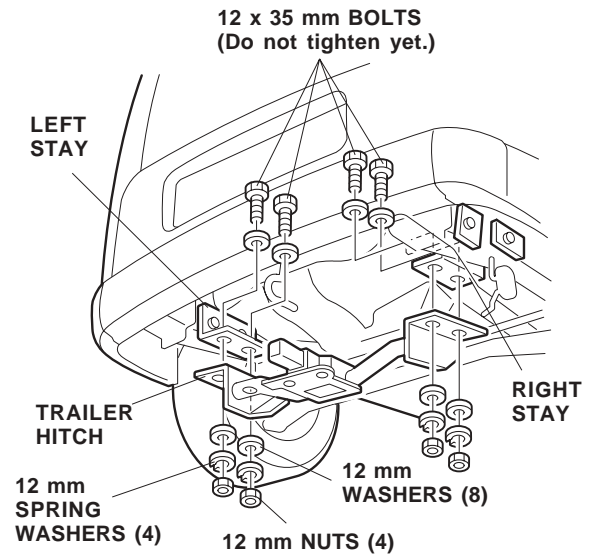

46. Insert the U-bolt around the tow hook and into the holes of the hook plate. Install an 8 mm washer, an 8 mm spring washer and an 8 mm nut on each end. Do not tighten yet.

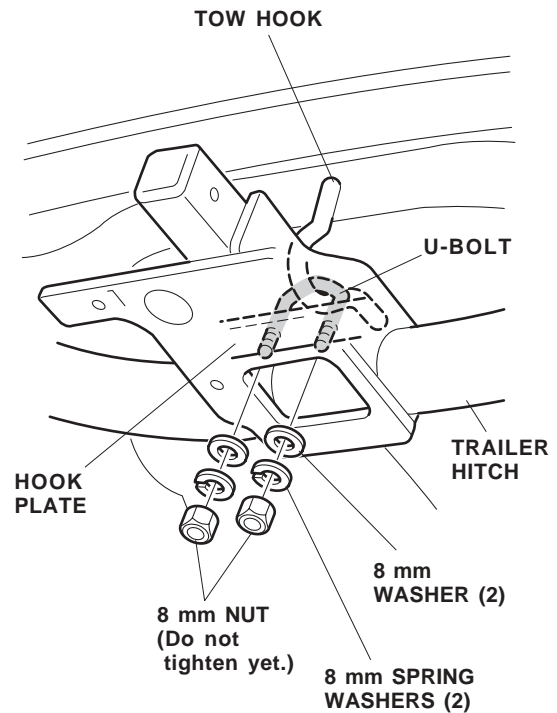

47. Torque all bolts and nuts to their specified torques in the order **1**, **2** and **3**.

1

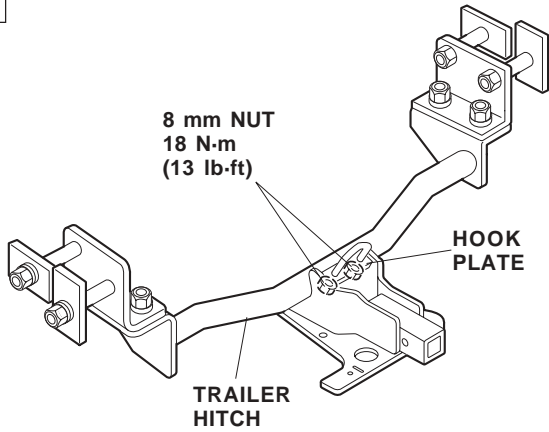

2

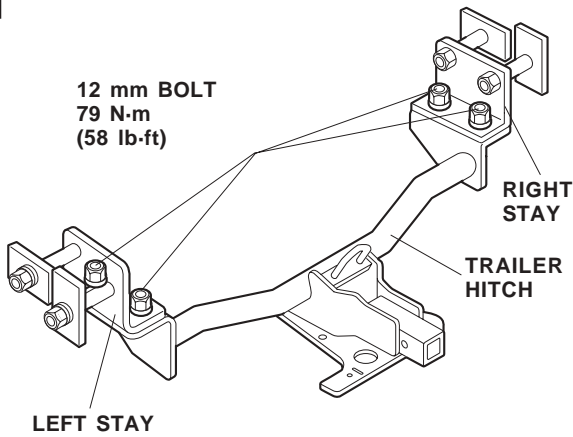

3

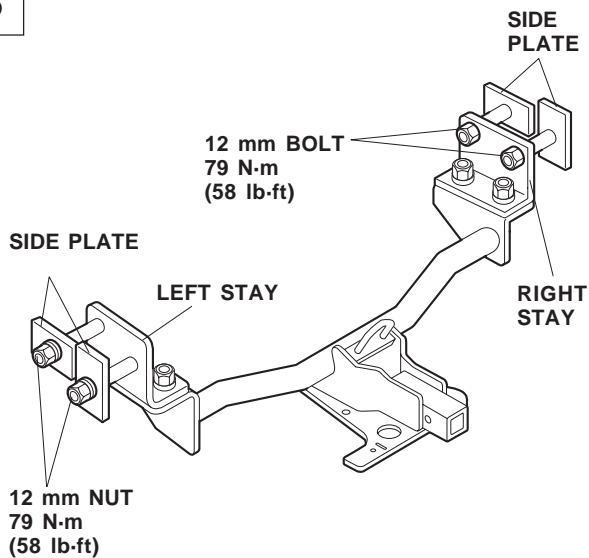

48. Slide the ball mount into the trailer hitch. Align the holes in the trailer hitch with the holes in the ball mount, then insert the retaining pin into the holes. Secure the retaining pin with the retaining clip.

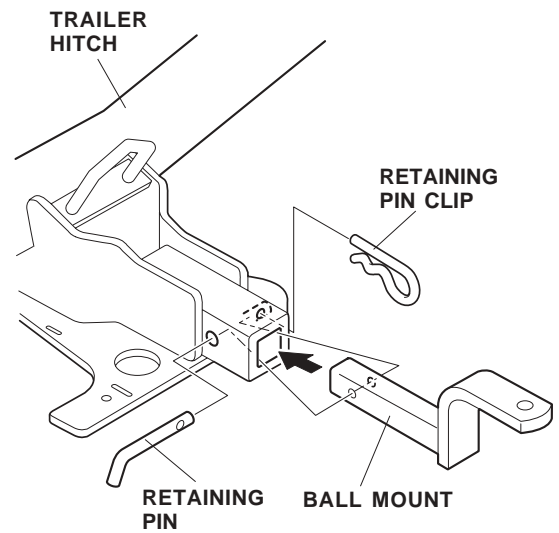

49. Route the trailer harness 4-pin connector to the hitch plate along the trailer hitch.

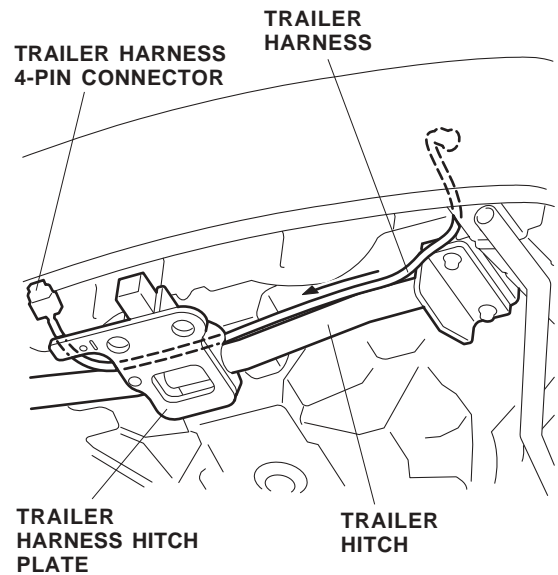

50. Install the connector bracket on the trailer harness 4-pin connector and secure them to the trailer hitch with the flange bolt and flange nut.

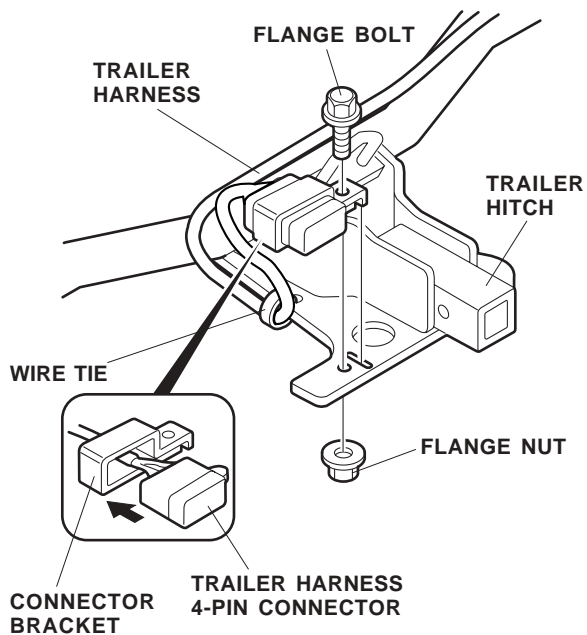

51. Secure the trailer harness to the trailer hitch with one wire tie.
52. Secure the trailer harness to the trailer hitch and to the vehicle panel with five wire ties in the areas shown.

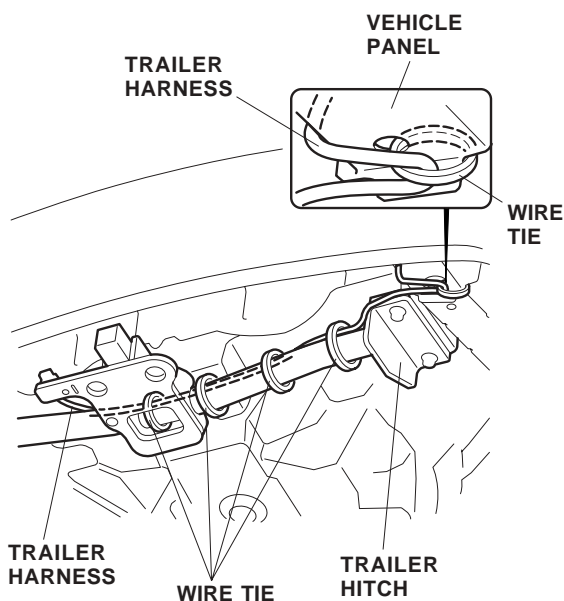

53. Check that all wire harnesses are routed properly and all connectors are plugged in.
54. Reconnect the negative cable to the battery.
55. Enter the customer's radio anti-theft code, and reset the radio station presets.
56. Reset the clock.
57. Reinstall all removed parts. Torque the seat belt anchor bolts to 30 - 34 N·m (22 - 25 lb·ft).

NOTE: After about 620 miles (1,000 km) of use, retighten the bolts and nuts to the specified torque.

58. If equipped, reinstall the splash guards.

NOTE: Whenever the battery is disconnected, the driver's window AUTO function is disabled.

59. Start the engine. Push down on the driver's window switch until the window is fully open.
60. Pull up on the driver's window switch to close the window completely, then hold the switch for 2 seconds.
61. Lower and raise the window to check the operation of the driver's window AUTO function.
62. Do the PCM idle learn procedure.

- Make sure all electrical items are turned off.
- Start the engine. Hold the engine speed at 3,000 rpm with no load (in Park or Neutral) until the radiator fan comes on.
- Let the engine idle for about 5 minutes with the throttle fully closed and with all electrical items off.

NOTE: If the radiator fan comes on during this step, the time it is operating must not be included in the 5 minutes.

Put a Copy of This Page in the Glove Box for Your Customer

Installing the Receiver Cover

Whenever you remove the retaining pin clip, the retaining pin and the ball mount, securely store them in the cargo area. Press the receiver cover into the opening at the end of the trailer hitch. When you reinstall the ball mount, store the receiver cover in the cargo area.

