



INSTALLATION INSTRUCTIONS

Accessory

TRUNK SPOILER

Application

2003-2004 ACCORD
2-DOOR

Publications No.

All 24089

Issue Date

SEP 2002

PARTS LIST

Trunk spoiler

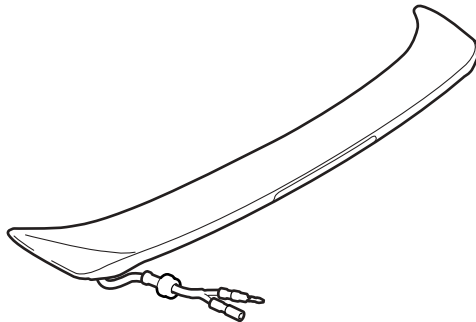

Spoiler harness

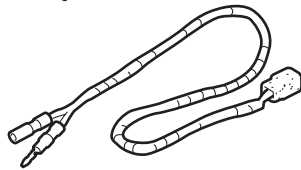

Right trunk spring
(marked red)

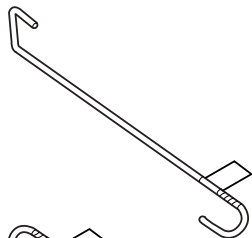

Left trunk spring
(marked yellow)

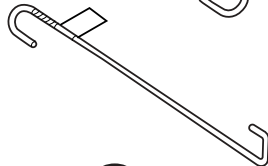

2 Washer-screws



Template

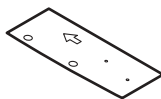

4 Cap nuts



14 Wire ties

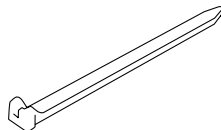

2 Rubber cushions

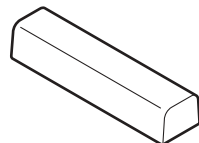

TOOLS AND SUPPLIES REQUIRED

Small flat-tip screwdriver

Eye protection (face shield, safety goggles, etc.)

Drill

3 mm, 8 mm, and 10 mm Drill bits

Drill stop

10 mm Combination wrench

Felt-tip pen

Paint pen

Center-punch

Deburring pen

Touch-up paint

Piece of wire

10 mm Socket

Torque wrench

Diagonal cutters

Gloves

Trunk Spring Installer/Remover:

T/N 08M10-SM4-100

Isopropyl alcohol

Shop towel

Tape measure

Utility knife

INSTALLATION

Customer information: The information in this installation instruction is intended for use only by skilled technicians who have the proper tools, equipment, and training to correctly and safely add equipment to your car. These procedures should not be attempted by "do-it-yourselfers."

NOTE: Wash and wax the area to be covered with a high-quality paste wax.

1. Make sure you have the anti-theft code for the radio, then write down the frequencies for the preset buttons.
2. Disconnect the negative cable from the battery.

Installing the Trunk Spoiler

3. Open the trunk lid. If equipped, remove the trunk lid cover (14 clips).

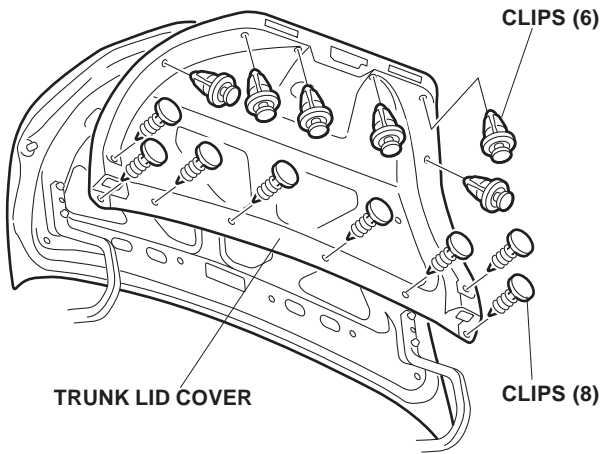

4. Inside trunk lid, locate the two identification marks on the trunk lid. Lightly center-punch each mark.

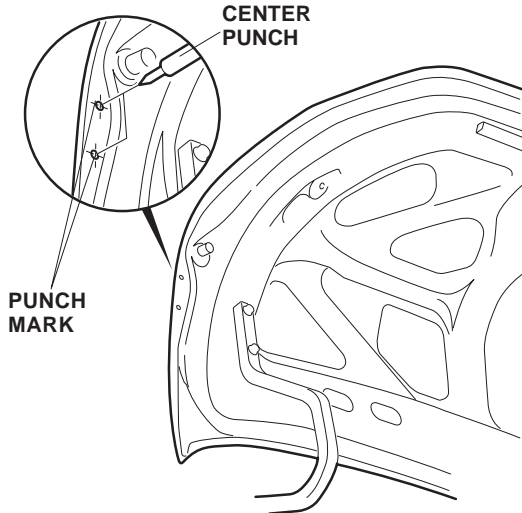

5. Have an assistant hold the trunk lid open. While wearing eye protection, drill an 8 mm hole through each mark:

- To prevent the metal shavings from falling on to the trunk floor, place a cover over the trunk floor.
- First drill with a 3 mm drill bit, and finish with an 8 mm drill bit.
- Remove all burrs and metal shavings, and apply touch-up paint to the edges of the holes.
- When the touch-up paint is dry, clean the area to be covered, and wax it with a high-quality paste wax.

First drill with a 3 mm drill bit, and finish with an 8 mm drill bit.

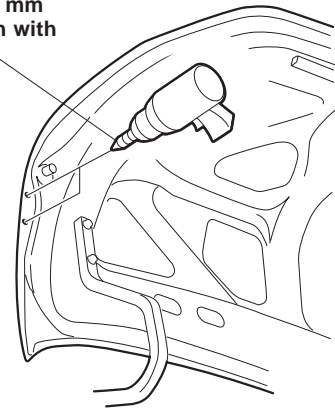

6. Using a paint pen, make a small mark across the rubber stopper and trunk lid, then remove the stopper.

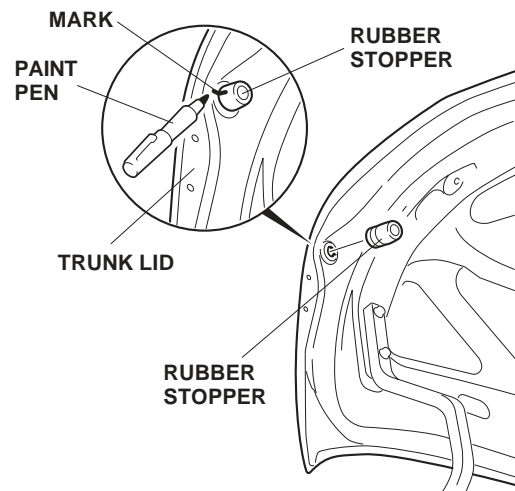

7. Repeat steps 4 thru 6 on the right side.

- Close the trunk lid. Position the template, printed side up, at the left (driver's side) edge of the trunk lid. Align the two outer holes in the template with the two holes in the trunk lid. Using a felt-tip pen, mark the trunk lid as indicated on the template. Make two marks on the left side.

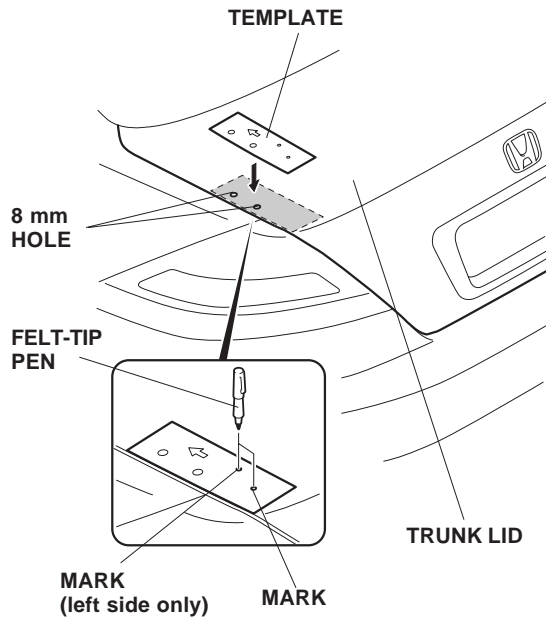

- Flip the template over and position it over the two holes on the right side. Using a felt-tip pen, mark only the rear hole. Make only one mark on the right side.

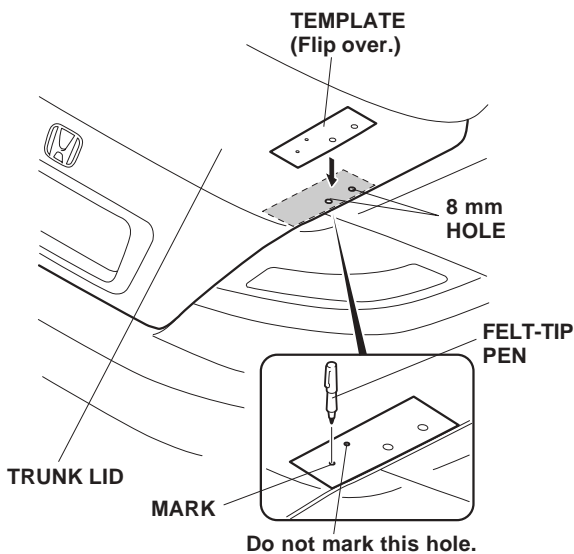

- Remove the template, and lightly center-punch all of the marks.

- While wearing eye protection, drill a 10 mm and an 8 mm hole at the center-punched marks through the outer skin of the trunk lid. The 10 mm hole on the left side is for routing the spoiler harness through the trunk lid. Use a drill stop to avoid drilling through the inner panel:

- 10 mm hole: First drill with a 3 mm drill bit, and finish with a 10 mm drill bit.
- 8 mm hole: First drill with a 3 mm drill bit, and finish with an 8 mm drill bit.
- Remove all burrs and metal shavings, and apply touch-up paint to the edge of the hole you drilled. Allow the touch-up paint to dry thoroughly before proceeding to the next step.

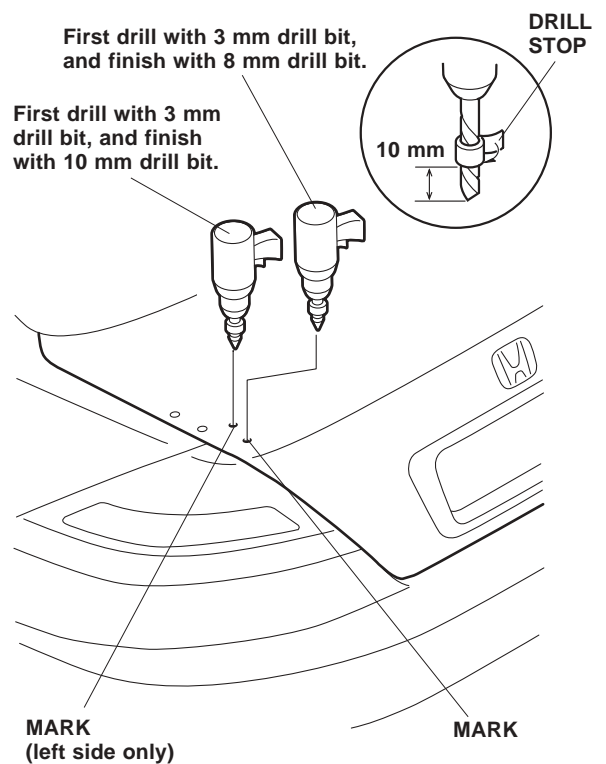

- Hold the trunk spoiler above the trunk lid, and route the trunk spoiler harness down through the 10 mm hole. Seat the rubber grommet into the 10 mm hole; then route the trunk spoiler harness through the rectangular hole of the inner trunk lid. If necessary, use a piece of wire to pull the harness through the trunk lid.

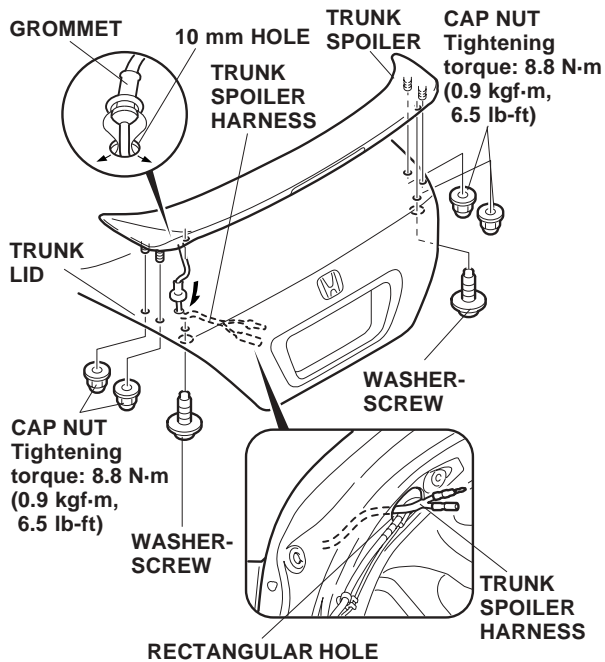

- Fit the trunk spoiler into position on the trunk lid, and install the four cap nuts and two washer-screws. Torque the cap nuts to 8.8 N-m (0.9 kgf-m, 6.5 lb-ft).
- Get the rubber stoppers removed in step 6. Using diagonal cutters, cut the tip off of the rubber stoppers.

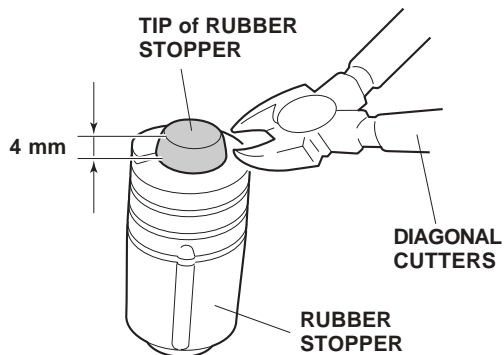

- Reinstall the rubber stoppers by aligning them with the marks on the body.

Installing the Trunk Spring

- Open the trunk, and remove the center clip from the trunk springs.

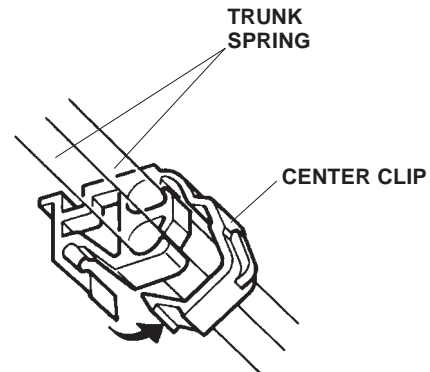

- With an assistant holding the trunk lid open, remove the old trunk springs from the trunk hinge arms using the special tool. Wear gloves to protect your hands, and pull the special tool slowly and carefully toward you.

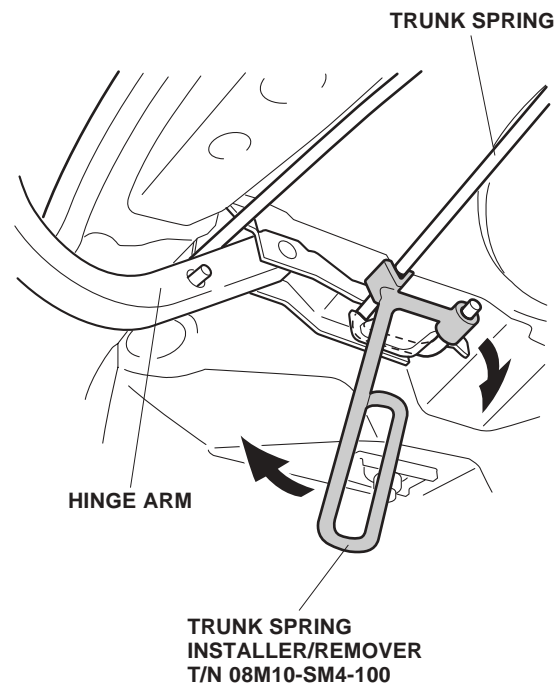

18. Install the right trunk spring and the left trunk spring in the reverse order of removal:
 - Set the tool on the marked end of each trunk spring.
 - Install the red-marked spring in the slot in the right (passenger's) side trunk hinge arm and to the hinge bracket on the left (driver's) side of the car; install the yellow-marked spring in the slot in the left (driver's) side trunk hinge arm and to the hinge bracket on the right (passenger's) side of the car.
 - Wearing gloves, rotate the tool as you pull it toward you.
 - Set the springs in the first notch (original position) of the hinge brackets.

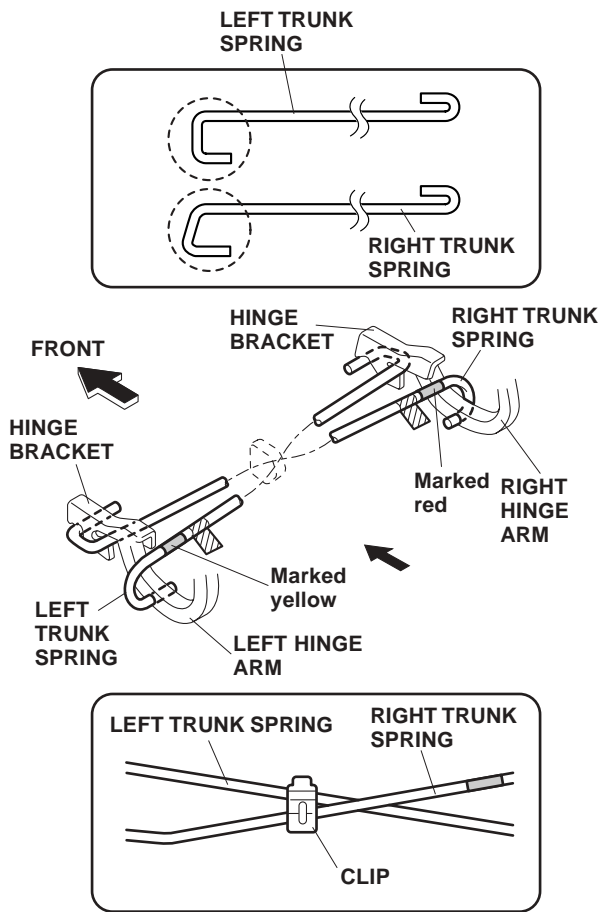

19. Reinstall the center clip on the trunk springs.

Routing the Spoiler Harness

20. Unplug the vehicle harness 2-pin connector from the high-mount brake light.

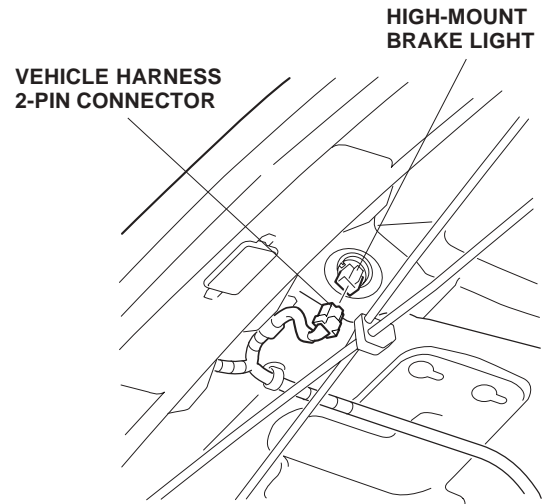

21. Route the spoiler harness above trunk springs, and plug the vehicle harness 2-pin connector into the spoiler harness 2-pin connector. Secure the 2-pin connector to the vehicle harness with one wire tie in the area shown.

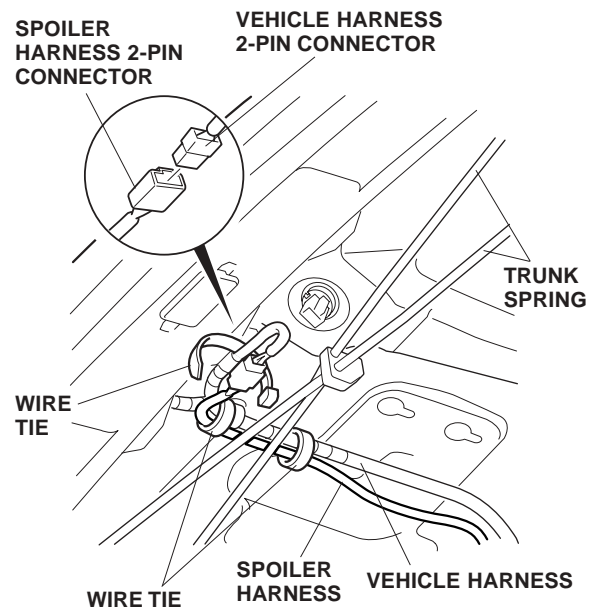

22. Secure the spoiler harness to the vehicle harness with two wire ties in the areas shown away from the trunk springs.

23. Gently pull down the left side trunk lining, and route the spoiler harness alongside the vehicle harness, and secure it with five wire ties in the area shown. If the car you are working on is equipped with the navigation system, secure the spoiler harness with four wire ties.

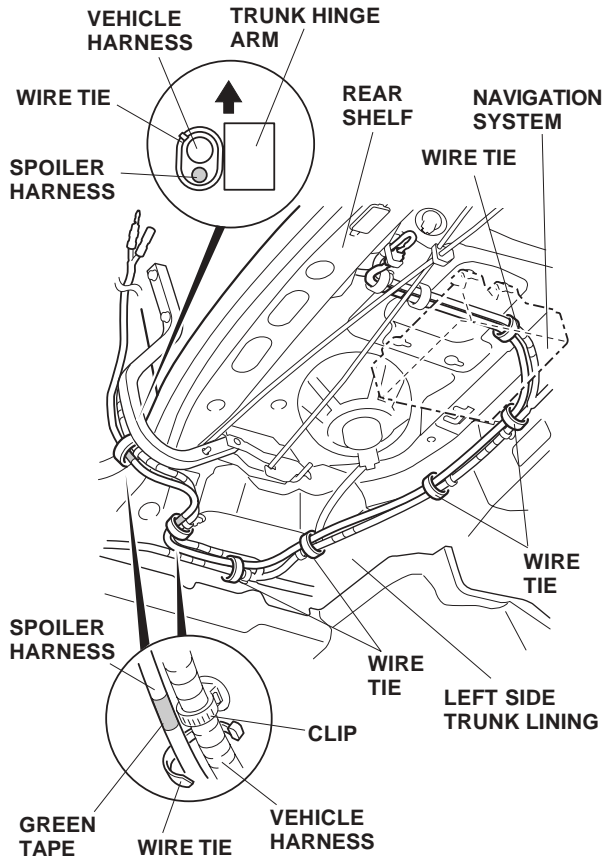

24. Locate the two clips on the vehicle harness attached to the rear shelf and the trunk hinge arm. Align the green tapes on the spoiler harness with the clips on the vehicle harness, and secure the spoiler harness to the vehicle harness with two wire ties.

25. Continue routing the spoiler harness up the trunk hinge arm and alongside the vehicle harness.

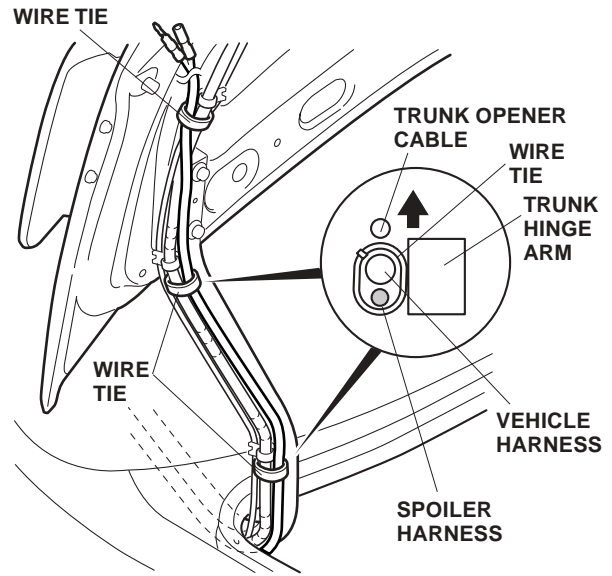

26. Secure the spoiler harness with three wire ties in the area shown. Do not secure the spoiler harness to the trunk opener cable.
27. Plug the spoiler harness terminals into the trunk spoiler harness terminals.

TRUNK SPOILER HARNESS TERMINAL

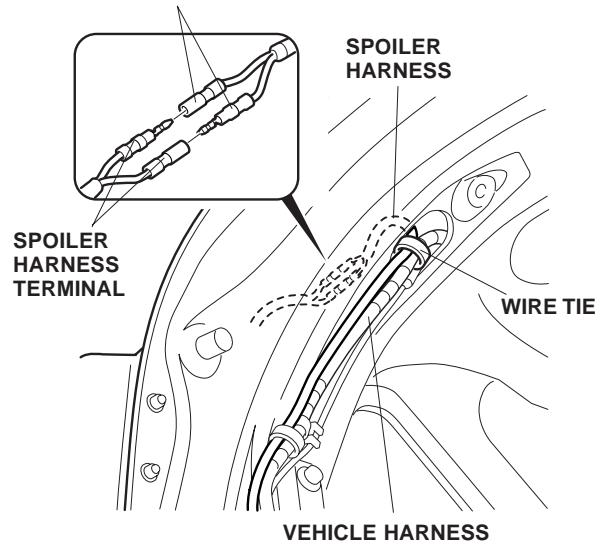

28. Tuck the spoiler terminals back in the hole in the trunk lid. Secure the spoiler harness to the vehicle harness with one wire tie near the hole.

29. Using isopropyl alcohol on a shop towel, clean the areas where the rubber cushions will attach.
30. Remove the adhesive backing from the rubber cushion, and attach it to the inside panel of the trunk lid next to the existing rubber cushion. Use the palm of your hand to hold pressure against them for 30 seconds. Repeat on the right side.

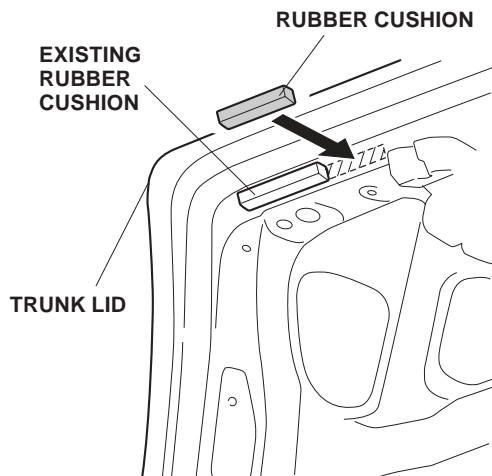

If the car was equipped with a trunk lid cover; continue with step 31, if not, go to step 32.

31. Using a tape measure and felt-tip pen, measure and mark the trunk lid cover. Using a utility knife, cut out the marked areas from the trunk lid cover.

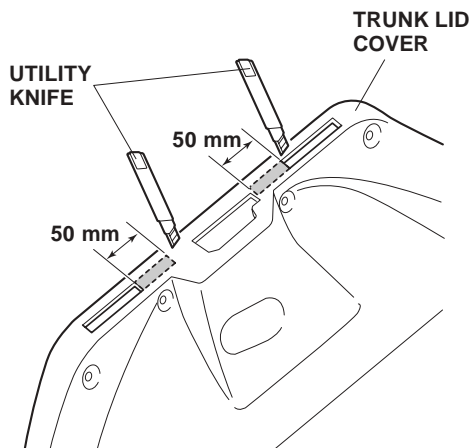

32. Check that all wire harnesses are routed properly and all connectors are plugged in.
33. If equipped, reinstall the trunk lid cover when the car you are working on is equipped with it.
34. Reconnect the negative cable to the battery.
35. Enter the customer's radio anti-theft code, and reset the radio station presets.
36. Reset the clock.
37. Press the brake pedal, and check that the spoiler brake light comes on.
38. Open the trunk lid, and make sure the trunk lid stays open on its own. If it won't, adjust the trunk springs to the second position.

NOTE: Whenever the battery is disconnected, the driver's window AUTO function is disabled.

39. Start the engine. Push down on the driver's window switch until the window is fully open.
40. Pull up on the driver's window switch to close the window completely, then hold the switch for two seconds.
41. Test the window AUTO function.

USE AND CARE

- Handle the spoiler with care. It is not designed to absorb impact.
- Do not open or close the trunk lid by grasping the spoiler.
- Check the spoiler mounting nuts periodically, and retighten them if necessary.