

**INSTALLATION
INSTRUCTIONS**

Accessory

**ENGINE COVER
P/N 08F48-S5T-100**

Application

2002-2005 CIVIC Si

Publications No.

All 27941

Issue Date

AUG 2004**PARTS LIST**

Engine cover

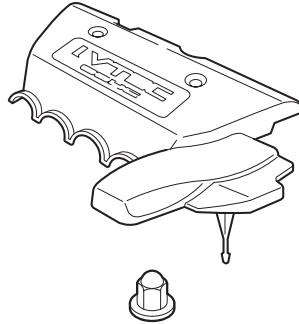

4 Cap nuts

TOOLS REQUIRED

Ratchet

10 mm Socket

Torque wrench

INSTALLATION

1. Open the hood.
2. Remove the two bolts that secure the engine cover, and remove the engine cover.

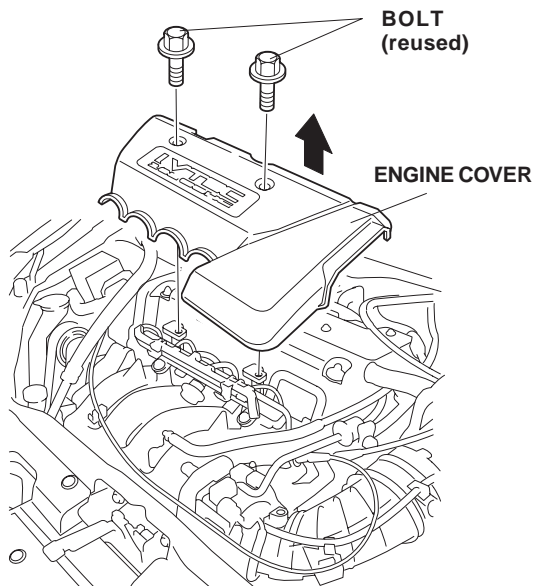

3. Position the new engine cover over the engine with its locating tab inserted into the hole in the engine, then reinstall the two bolts. Torque the two bolts to 12 N·m (9 lb-ft).

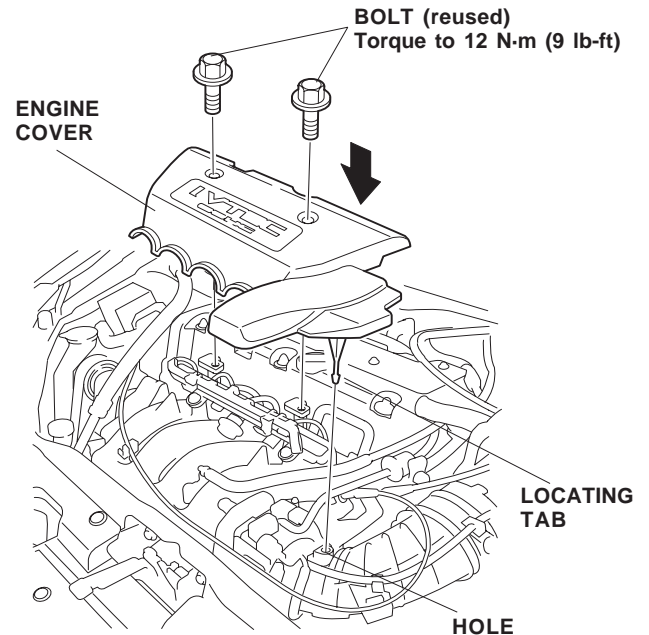

4. Remove and discard the four cap nuts from the PHC cover. Install the four cap nuts from the kit. Torque each cap nut to 12 N·m (9 lb-ft).

NOTE: If the stud bolts come out with the front nuts, separate the bolts and nuts, and reinstall the bolts first.

